



Bangladesh Telecommunications Company Limited

**TENDER DOCUMENT
FOR THE PROCUREMENT OF GOODS**

**Supply, Installation, Testing and Commissioning of Video
conferencing system for District, Divisional and Central
Administrations**

Tender No: DP/L-../

Issued on: -04-2010

Tender Package No: x

Office of the Director Procurement
Sher-e-Bangla Nagar Telephone Exchange Annex Bldg (2nd Floor)
Sher-e-Bangla Nagar, Dhaka.

Table of Contents

Section 1. Instructions to Tenderers	1
A. General.....	1
1. Scope of Tender.....	1
2. Source of Funds.....	1
3. Corrupt, Fraudulent, Collusive or Coercive Practices.....	1
4. Eligible Tenderers.....	2
5. Eligible Goods and Related Services.....	3
6. Site Visit.....	3
B. Tender Document	4
7. Tender Document: Sections.....	4
8. Tender Document: Clarification.....	4
9. Tender Document: Pre-Tender Meeting.....	4
10. Tender Document: Amendment.....	5
C. Qualification Criteria	5
11. General Criteria.....	5
12. Experience Criteria.....	5
13. Financial Criteria.....	6
D. Tender Preparation.....	6
14. Tender : Only One.....	6
15. Tender: Preparation Costs.....	6
16. Tender: Language.....	6
17. Tender: Contents of Tender.....	6
18. Tender: Submission Sheet, Price Schedules and Specifications Submission Sheet.....	7
19. Tender: Alternatives.....	7
20. Tender: Prices and Discounts.....	7
21. Tender: Currency.....	8
22. Tenderer: Documents Establishing Eligibility.....	9
23. Goods and Related Services: Documents Establishing Eligibility.....	9
24. Tenderers: Documents Establishing Qualifications.....	9
25. Tenderer: Disqualification.....	10
26. Tender: Validity.....	11
27. Tender: Security.....	11
28. Tender Format and Signing.....	12
E. Tender Submission	12
29. Tender: Sealing and Marking.....	12
30. Tender: Submission Deadline.....	13
31. Tender: Submitted Late.....	13
32. Tender: Modification, Substitution or Withdrawal.....	13
F. Tender Opening and Evaluation	14
33. Tender: Opening.....	14
34. Tender: Confidentiality.....	14
35. Tender: Clarification.....	14
36. Tenderer: Contacting the Purchaser.....	15
37. Tender: Responsive ness.....	15
38. Tender: Non-conformities, Errors, and Omissions.....	15
39. Tender: Correction of Arithmetical Errors.....	16
40. Tender: Preliminary Examination.....	16
41. Tender: Technical Evaluation.....	16
42. Tender: Financial Evaluation.....	17
43. Tender: No Negotiation.....	19
44. Tender: Comparison.....	19
45. Tenderer: Post-qualification.....	20
46. Tenders: Purchaser's Right to Accept or to Reject Any or All.....	20
G. Contract Award	20
47. Award Criteria.....	20
48. Purchaser's Right to Vary Quantities.....	20
49. Notification of Award.....	20

50.	Performance Security	20
51.	Contract: Signing	21
52.	Advising Unsuccessful Tenderers	21
53.	Tenderer: Right to Complain	21
Section 2.	Tender Data Sheet	22
A.	General	22
B.	Tender Document	22
C.	Qualification Criteria	23
D.	Preparation of Tender	23
E.	Submission of Tender	25
F.	Opening and Evaluation of Tenders	25
G.	Award of Contract.....	26
Section 3.	General Conditions of Contract	27
1.	Definitions.....	27
2.	Contract Documents.....	28
3.	Corrupt, Fraudulent, Collusive or Coercive Practices	28
4.	Interpretation	29
5.	Documents Forming the Contract and Priority of Documents	30
6.	Eligibility	30
7.	Governing Language	30
8.	Governing Law	30
9.	Gratuities / Agency fees	31
10.	Joint Venture, Consortium or Association (JVCA)	31
11.	Confidential Information	31
12.	Communications and Notices	32
13.	Patent and Intellectual Property Rights	32
14.	Copyright	33
15.	Assignment.....	33
16.	Sub contracting	33
17.	Supplier's Responsibilities.....	33
18.	Purchaser's Responsibilities.....	33
19.	Scope of Supply	33
20.	Change Orders and Contract Amendments	33
21.	Packing and Documents	34
22.	Delivery and Documents and Acceptance.....	34
23.	Contract Price.....	35
24.	Transportation	35
25.	Spare Parts	35
26.	Terms of Payment	35
27.	Insurance.....	36
28.	Taxes and Duties	36
29.	Performance Security	36
30.	Specifications and Standards	36
31.	Inspections and Tests	37
32.	Warranty.....	38
33.	Extensions of Time.....	38
34.	Liquidated Damages	39
35.	Limitation of Liability	39
36.	Change in Laws and Regulations.....	39
37.	Force Majeure	39
38.	Termination	40
39.	Settlement of Disputes	41
Section 4.	Particular Conditions of Contract	42
Section 5.	Tender and Contract Forms	47
Tender Submission Sheet (Form G – 1).....		48
Price Schedule for Goods (Form G-2A)		49

Price Schedule for Related Services (Form G-2B)	52
Specifications Submission Sheet (Form G-3)	54
Tenderer Information Sheet (Form G-4)	55
Manufacturer’s Authorisation Letter (Form G - 5)	58
Bank Guarantee for Tender Security (Form G – 6)	59
Notification of Award (Form G - 7)	60
Contract Agreement (Form G - 8)	61
Bank Guarantee for Performance Security (Form G – 9)	62
Bank Guarantee for Advance Payment (Form G – 10)	63
Section 6. Schedule of Requirements	64
Section 7 : Technical Specifications	67
Section 8 : Drawings	105

Invitation for Tenders

GOVERNMENT OF THE PEOPLE'S REPUBLIC OF BANGLADESH					
1	Ministry/Division	MOPT			
2	Agency	Bangladesh Telecommunications Company Limited			
3	Procuring Entity Name	XXXXXXXXXX			
4	Procuring Entity Code	XXXX			
5	Procuring Entity District	Dhaka			
6	Invitation for	Goods			
7	Invitation Ref No				
8	Date				
KEY INFORMATION					
9	Procurement Method	OTM (Open Tendering Method)			
FUNDING INFORMATION					
10	Budget and Source of Funds	GOB			
11	Development Partners (if applicable)	Not Applicable			
PARTICULAR INFORMATION					
12	Project / Programme Code (if applicable)	-			
13	Project / Programme Name (if applicable)	Supply, Installation, Testing and Commissioning of Video conferencing system for District, Divisional and Central Administrations			
14	Tender Package No.	-			
15	Tender Package Name	-			
		Date			
16	Tender Publication Date				
17	Tender Last Selling Date				
		Date		Time	
18	Tender Closing Date and Time				
19	Tender Opening Date and Time				
20	Name & Address of the office(s) - Selling Tender Document (Principal) - Selling Tender Document (Others) - Receiving Tender Document - Opening Tender Document	XXXXXXXXXXXXXXXXXX			
		-			
		As above.			
		As above.			
21	Place / Date / Time of Pre-Tender Meeting (Optional)	None.			
INFORMATION FOR TENDERER					
22	Eligibility of Tenderer	As mentioned in tender document.			
23	Brief Description of Goods & Related services :	Supply, Installation, Testing and Commissioning of Video conferencing system for District, Divisional and Central Administrations			
24	Brief Description of Related Services	As mentioned in 23			
25	Price of Tender Document (Tk)	XXXXXXX			
	Lot No	Identification of Lot	Location	Tender Security Amount (Tk)	Completion Time in Weeks
	Single	As mentioned in sl 13	As on sl no. 20	XXXXXXXX	XX
PROCURING ENTITY DETAILS					
30	Name of Official Inviting Tender				
31	Designation of Official Inviting Tender				
32	Address of Official Inviting Tender				
33	Contact details of Official Inviting Tender				
34	The procuring entity reserves the right to accept or reject all tenders				

Section 1. Instructions to Tenderers

A. General

1. Scope of Tender
 - 1.1 The Purchaser, as indicated in the Tender Data Sheet (TDS), issues this Tender Document for the supply of Goods, and Related Services incidental thereto, as specified in the TDS and as detailed in Section 6: Schedule of Requirements. The name of the Tender and the number and identification of its constituent lot(s) are stated in the TDS.
 - 1.2 The successful Tenderer will be required to complete the delivery of the goods and related services (when applicable) as specified in the Particular Conditions of Contract (PCC).
 - 1.3 Throughout this Tender Document:
 - (a) the term “in writing” means communicated in written form with proof of receipt;
 - (b) if the context so requires, singular means plural and vice versa; and
 - (c) “day” means calendar day.
2. Source of Funds
 - 2.1 The Purchaser has been allocated public funds as indicated in the TDS and intends to apply a portion of the funds to eligible payments under the contract for which this Tender Document is issued.
 - 2.2 For the purpose of this provision, “public funds” means any monetary resources appropriated to procuring entities under Government budget, or revenues generated by statutory bodies and corporations or aid grants and credits put at the disposal of procuring entities by the development partners through the Government.
 - 2.3 Payments by the development partner, if so indicated in the TDS, will be made only at the request of the Government and upon approval by the development partner in accordance with the applicable Loan/Credit/Grant Agreement, and will be subject in all respects to the terms and conditions of that Agreement.
3. Corrupt, Fraudulent, Collusive or Coercive Practices
 - 3.1 The Government requires that Purchasers, as well as Tenderers and Suppliers shall observe the highest standard of ethics during the implementation of procurement proceedings and the execution of contracts under public funds.
 - 3.2 In pursuance of this requirement, the Purchaser shall:
 - (a) exclude the Tenderer from participation in the procurement proceedings concerned or reject a proposal for award; and
 - (b) declare a Tenderer ineligible, either indefinitely or for a stated period of time, from participation in procurement proceedings under public funds;

if it, at any time, determines that the Tenderer has engaged in corrupt, fraudulent, collusive or coercive practices in competing for, or in executing, a contract under public funds.

3.3 Should any corrupt, fraudulent, collusive or coercive practice of any kind come to the knowledge of the Purchaser, it shall, in the first place, allow the Tenderer to provide an explanation and shall, take actions only when a satisfactory explanation is not received. Such exclusion and the reasons thereof, shall be recorded in the record of the procurement proceedings and promptly communicated to the Tenderer concerned. Any communications between the Tenderer and the Purchaser related to matters of alleged fraud or corruption shall be in writing.

3.4 The Government defines, for the purposes of this provision, the terms set forth below as follows:

(a) "*corrupt practice*" means offering, giving, or promising to give, directly or indirectly, to any officer or employee of a Procuring Entity or other governmental/private authority or individual, a gratuity in any form, an employment, or any other thing or service of value, as an inducement with respect to an act or decision of, or method followed by, a Procuring Entity in connection with the procurement proceeding;

(b) "*fraudulent practice*" means a misrepresentation or omission of facts in order to influence a procurement proceeding or the execution of a contract to the detriment of the Purchaser;

(c) "*collusive practice*" means a scheme or arrangement among two or more Tenderers, with or without the knowledge of the Purchaser (prior to or after Tender submission), designed to establish Tender prices at artificial, non-competitive levels and to deprive the Purchaser of the benefits of free, open and genuine competition; and

(d) "*coercive practice*" means harming or threatening to harm, directly or indirectly, persons or their property to influence the procurement proceedings, or affect the execution of a contract.

3.5 The Tenderer shall be aware of the provisions on fraud and corruption stated in GCC Clause 3 and GCC Sub-Clause 38.1(c).

3.6 The Government requires that the Purchaser's personnel have an equal obligation not to solicit, ask for and/or use coercive methods to obtain personal benefits in connection with the said proceedings.

4. Eligible Tenderers

4.1 This Invitation for Tenders is open to eligible Tenderers from all countries, except for any specified in the TDS.

4.2 A Tenderer may be a physical or juridical individual or body of individuals, or company, association or any combination of them under agreement in the form of an intended or existing joint venture, consortium or association (JVCA), invited to take part in public procurement or seeking to be so invited or submitting a Tender in

response to an Invitation for Tenders. All members of the JVCA shall be jointly and severally liable to the Purchaser. JVCA is distinct from Supplier, Sub-supplier arrangement where the entire responsibility for contract execution rests with the Supplier.

- 4.3 A Government-owned enterprise in Bangladesh may also participate in the Tender if it is legally and financially autonomous, it operates under commercial law, and it is not a dependent agency of the Purchaser.
- 4.4 The Tenderer shall provide in Section 5: Tender and Contract Forms, a statement that the Tenderer (including all members of a JVCA) is not associated, nor has been associated in the past, directly or indirectly, with a consultant or any other entity that has prepared the specifications and other documents for this Invitation for Tenders.
- 4.5 The Tenderer shall not be under a declaration of ineligibility for corrupt, fraudulent, collusive or coercive practices in accordance with ITT Sub-Clause 3.2.
- 4.6 The Tenderer with a consistent history of litigation or a number of arbitration awards against it, shall not be eligible to Tender. The Tenderer shall supply the information requested in para 3.3 of the Tenderer Information Sheet (Form G-4)
- 4.7 The Tenderer shall have the legal capacity to enter into the contract.
- 4.8 The Tenderer shall not be insolvent, be in receivership, be bankrupt or being wound up, its business activities shall not be suspended, and it shall not be the subject of legal proceedings for any of the foregoing.
- 4.9 The Tenderer shall have fulfilled its obligations to pay taxes and social security contributions under the relevant national laws and regulations.
- 5. Eligible Goods and Related Services
 - 5.1 All goods and related services to be supplied under the contract are eligible, unless their origin is from a country specified in the TDS.
 - 5.2 For purposes of this clause, "origin" means the place where the goods are mined, grown, or produced, or the place from which the related services are supplied.
 - 5.3 The origin of goods and services is distinct from the nationality of the Tenderer.
- 6. Site Visit
 - 6.1 For goods contracts requiring installation/ commissioning/ networking or similar services at site, the Tenderer, at the Tenderer's own responsibility and risk, is encouraged to visit and examine the Site and obtain all information that may be necessary for preparing the Tender and entering into a contract for the supply of goods and related services.
 - 6.2 The Tenderer should ensure that the Purchaser is informed of the visit in adequate time to allow it to make appropriate arrangements.
 - 6.3 The costs of visiting the Site shall be at the Tenderer's own expense.

B. Tender Document

- | | |
|--|--|
| 7. Tender Document: Sections | <p>7.1 The Sections comprising the Tender Document are listed below and should be read in conjunction with any Amendment issued in accordance with ITT Clause 10.</p> <ul style="list-style-type: none">• Section 1 Instructions to Tenderers (ITT)• Section 2 Tender Data Sheet (TDS)• Section 3 General Conditions of Contract (GCC)• Section 4 Particular Conditions of Contract (PCC)• Section 5 Tender and Contract Forms• Section 6 Schedule of Requirements• Section 7 Technical Specifications• Section 8 Drawings <p>7.2 The Purchaser will reject any Tender submission if the Tender Document was not purchased directly from the Purchaser, or through its agent as stated in the TDS.</p> <p>7.3 The Tenderer is expected to examine all instructions, forms, terms, and specifications in the Tender Document as well as in Tender Amendments, if any. Failure to furnish all information or documentation required by the Tender Document may result in the rejection of the Tender.</p> |
| 8. Tender Document: Clarification | <p>8.1 A prospective Tenderer requiring any clarification of the Tender Document shall contact the Purchaser in writing at the Purchaser's address indicated in the TDS. The Purchaser will respond in writing to any request for clarification received no later than seven (7) days prior to the deadline for submission of Tenders.</p> <p>8.2 The Purchaser shall forward copies of its response to all those who have purchased the Tender Document, including a description of the enquiry but without identifying its source.</p> <p>8.3 Should the Purchaser deem it necessary to amend the Tender Document as a result of a clarification, it shall do so following the procedure under ITT Clause 10 and ITT Sub-Clause 30.3.</p> |
| 9. Tender Document: Pre-Tender Meeting | <p>9.1 To clarify issues and to answer questions on any matter arising in the Tender Document, the Purchaser may, if stated in the TDS, invite prospective Tenderers to a Pre-Tender Meeting at the place, date and time as specified in the TDS. Tenderers are encouraged to attend the meeting, if it is held.</p> <p>9.2 The Tenderer is requested to submit any questions in writing so as to reach the Purchaser not later than five (5) days prior to the date of the</p> |

meeting.

- 9.3 Minutes of the pre-Tender meeting, including the text of the questions raised and the responses given, together with any responses prepared after the meeting, will be transmitted within seven (7) days to all those who purchased the Tender Document. Any modification to the Tender Document listed in ITT Sub-Clause 7.1 that may become necessary as a result of the pre-Tender meeting shall be made by the Purchaser exclusively through the issue of an Amendment pursuant to ITT Clause 10 and not through the minutes of the pre-Tender meeting.
- 9.4 Non-attendance at the pre-Tender meeting will not be a cause for disqualification of a Tenderer.
10. Tender Document: Amendment
- 10.1 At any time prior to the deadline for submission of Tenders, the Purchaser for any reason, on its own initiative or in response to a clarification request in writing from a Tenderer, having purchased the Tender Document, may amend the Tender Document by issuing an amendment.
- 10.2 Any amendment issued shall become an integral part of the Tender Document and shall be communicated in writing to all those who have purchased the Tender Document.
- 10.3 To give a prospective Tenderer reasonable time in which to take an amendment into account in preparing its Tender, the Purchaser may, at its discretion, extend the deadline for the submission of Tenders, pursuant to ITT Sub-Clause 30.3. In the event that an amendment is issued with a period of only one-third or less of the Tendering period remaining, then the deadline for the submission of Tenders may be extended by the Purchaser, if so requested by a substantial number of Tenderers.

C. Qualification Criteria

11. General Criteria
- 11.1 The Tenderer shall possess the necessary professional and technical qualifications and competence, financial resources, production capability with equipment and other physical facilities, including after-sales service where appropriate, managerial capability, specific experience, reputation, and the personnel to perform the contract.
- 11.2 To qualify for a multiple number of lots in a package for which tenders are invited in the Invitation for Tenders, The Tenderer shall demonstrate having resources and experience sufficient to meet the aggregate of the qualifying criteria for the individual lots
12. Experience Criteria
- 12.1 The Tenderer shall have the following minimum level of supply experience to qualify for supplying the Goods and Related Services under the contract:
- (a) a minimum number of years of overall experience in the supply of goods and related services as specified in the TDS;
- (b) specific experience in the supplying of similar goods and

related services as specified in the TDS;

(c) a minimum production capacity or availability of equipment as specified in the TDS; and

(d) in case of a Tenderer offering to supply goods which the Tenderer did not manufacture or otherwise produce, the Tenderer has been duly authorized by the goods' manufacturer or producer to supply the goods.

13. Financial Criteria
- 13.1 The Tenderer shall have the following minimum level of financial capacity of qualify for the supply of goods under the contract:
- (a) The satisfactory completion of supply of similar goods of value stated in the TDS under a single contract in the last five years; and
 - (b) Availability of minimum liquid assets or working capital or credit facilities from a Bank, as specified in the TDS.

D. Tender Preparation

14. Tender : Only One
- 14.1 A Tenderer shall submit only one (1) Tender for each lot, either individually or as a Member in a JVCA. A Tenderer who submits or participates in more than one (1) Tender for each lot will cause all the Tenders with that Tenderer's participation to be rejected.
15. Tender: Preparation Costs
- 15.1 The Tenderer shall bear all costs associated with the preparation and submission of its Tender, and the Purchaser shall not be responsible or liable for those costs, regardless of the conduct or outcome of the Tendering process.
16. Tender: Language
- 16.1 The Tender, as well as all correspondence and documents relating to the Tender shall be written in the English or Bangla language, unless specified otherwise in the TDS. Supporting documents and printed literature furnished by the Tenderer may be in another language provided they are accompanied by an accurate translation of the relevant passages into the English or Bangla language, in which case, for purposes of interpretation of the Tender, such translation shall govern.
- 16.2 The Tenderer shall bear all costs of translation to the governing language and all risks of the accuracy of such translation.
17. Tender: Contents of Tender
- 17.1 The Tender prepared by the Tenderer shall comprise the following:
- (a) the Tender Submission Sheet (Form G-1);
 - (b) the Price Schedule (Form G-2) completed in accordance with ITT Clauses 18, 20 and 21;
 - (c) Original Tender Security (Form G-6) completed in accordance with ITT Clause 27;
 - (d) Specifications Submission Sheet (Form G-3) completed in

accordance with ITT Clause 18;

- (e) alternative Tenders, if permitted, in accordance with ITT Clause 19;
- (f) written confirmation authorising the signatory of the Tender to commit the Tenderer, in accordance with ITT Clause 28;
- (g) documentary evidence in accordance with ITT Clause 22 establishing the Tenderer's eligibility to Tender, including the Tenderer Information Sheet (Form G-4) and the Manufacturer's Authorisation Letter (Form G-5), when applicable;
- (h) documentary evidence in accordance with ITT Clauses 23 and 37 that the Goods and Related Services are of eligible origin and conform to the Tender Document;
- (i) documentary evidence in accordance with ITT Clause 24 establishing the Tenderer's qualifications to perform the contract if its Tender is accepted; and
- (j) any other document as specified in the TDS.

- | | |
|---|---|
| 18. Tender:
Submission
Sheet, Price
Schedules and
Specifications
Submission
Sheet | 18.1 The Tenderer shall submit the completed Tender Submission Sheet (Form G-1) as furnished in Section 5: Tender and Contract Forms. This document shall be completed without any alterations to its format, filling in all blank spaces with the information requested, failing which the tender may be rejected as being non-responsive. |
| | 18.2 The Tenderer shall submit the completed Price Schedule for Goods and Related Services (Form G-2) as furnished in Section 5: Tender and Contract Forms. |
| | 18.3 The Tenderer shall submit the completed Specifications Submission Sheet (Form G-3) as furnished in Section 5: Tender and Contract Forms. |
| | 18.4 All the documents mentioned in ITT Sub-Clauses 18.1 to 18.3 shall be completed without any alterations to their format, filling in all blank spaces with the information requested, failing which the Tender may be rejected as being non-responsive. |
| 19. Tender:
Alternatives | 19.1 Unless otherwise stated in the TDS, alternative Tenders shall not be considered. |
| 20. Tender: Prices
and Discounts | 20.1 The prices and discounts quoted by the Tenderer in the Tender Submission Sheet (Form G-1) and in the Price Schedule (Form G-2) shall conform to the requirements specified below. |
| | 20.2 All items for each lot, as listed in Section 6: Schedule of Requirements must be listed and priced separately on the Price Schedule (Form G-2). For any item listed in the Schedule of Requirements, but not shown in the Price Schedule, it shall be |

assumed that the item is not included in the Tender. For any item listed in the Schedule of Requirements, but shown unpriced in the Price Schedule, it shall be assumed that the price is included in the prices of other items. In all cases the Tender shall be evaluated in accordance with ITT Sub-Clause 20.3.

20.3 Tenders are being invited either for individual lots or for any combination of lots and prices quoted shall correspond to 100% of the items and quantities specified for each lot. If so indicated in the TDS Contracts may be awarded on a lot-by-lot basis and Tenderers wishing to offer any price reduction for the award of more than one Contract shall specify in their Tender the price reductions applicable to each lot or combination of lots.

20.4 The Tenderer shall indicate on the Price Schedule (Form G-2) the unit prices (where applicable) and the total price of the lot it proposes to supply under the contract.

20.5 Prices indicated on the Price Schedule shall be entered separately in the following manner:

(a) the price of the goods quoted EXW (ex works, ex factory, ex warehouse, ex showroom, or off-the-shelf, as applicable), including all customs duties and sales and other taxes already paid or payable : (i) on the components and raw materials used in the manufacture or assembly of goods quoted ex works or ex factory; or (ii) on the previously imported goods of foreign origin quoted ex warehouse, ex showroom or off-the-shelf;

(b) any Purchaser country local taxes (VAT and other taxes) which will be payable on the goods if the contract is awarded;

(c) the price for inland transportation, insurance, and other local costs incidental to delivery of the goods to their final destination, if specified in the TDS; and

(d) the price of other related (incidental) services, if any, listed in the TDS.

20.6 The Tenderer's separation of price components in accordance with ITT Sub-Clause 20.5 will be solely for the purpose of facilitating the comparison of Tenders by the Purchaser and will not in any way limit the Purchaser's right to contract on any of the terms offered.

20.7 Prices quoted by the Tenderer shall be fixed during the Tenderer's performance of the Contract and not subject to variation on any account, unless otherwise specified in the TDS.

21. Tender:
Currency

21.1 All prices shall be quoted in Bangladesh Taka.

-
22. Tenderer: Documents Establishing Eligibility
- 22.1 The Tenderer shall submit documentary evidence to establish its eligibility in accordance with ITT Clause 4 and, in particular, shall:
- (a) complete the eligibility declarations in the Tender Submission Sheet (Form G-1), furnished in Section 5: Tender and Contract Forms; and
 - (b) if in accordance with ITT Sub-Clause 4.2, the Tenderer is an existing or intended JVCA, it must submit the Tenderer Information Sheet (Form G-4) and a copy of the JV Agreement, or a letter of intent to enter into such an Agreement. The respective document shall be signed by all legally authorised signatories of all the parties to the existing or intended JVCA, as appropriate.
- 22.2 If so specified in the TDS, a Tenderer that does not manufacture or produce the Goods it offers to supply shall submit the Manufacturer's Authorisation Letter (Form G-5) furnished in Section 5: Tender and Contract Forms, to demonstrate that it has been duly authorised by the manufacturer or producer of the Goods to supply the Goods to Bangladesh.
23. Goods and Related Services: Documents Establishing Eligibility
- 23.1 To establish the conformity of the Goods and Related Services to the Tender Document, the Tenderer shall furnish as part of its Tender the documentary evidence that the goods conform to Section 7: Technical Specifications.
- 23.2 The documentary evidence may be in the form of literature, drawings or data, and shall consist of a detailed item by item description of the essential technical and performance characteristics of the Goods and Related Services, demonstrating the substantial responsiveness of the Goods and Related Services to those requirements of Section 7: Technical Specifications, and if applicable, a statement of deviations and exceptions. The Tenderer shall note that standards for workmanship, material, and equipment as well as references to brand names or catalogue numbers designated by the Purchaser in its Technical Specifications, are intended to be descriptive only and not restrictive. The Tenderer may substitute alternative standards/ brand names, etc. in its tender provided that it demonstrates to the Purchaser's satisfaction that substitutions ensure substantial equivalence.
- 23.3 The Tenderer shall also furnish a list giving full particulars, including available sources and current prices of spare parts, special tools, etc., necessary for the proper and continuing functioning of the goods for a period to be specified in the TDS, following commencement of the use of the goods by the Purchaser.
24. Tenderers: Documents Establishing Qualifications
- 24.1 Tenderers shall submit documentary evidence to meet the qualification criteria specified in Sub-Section C, Qualification Criteria of the ITT.
- 24.2 Tenderers shall submit the Tenderer Information Sheet (Form G-4) furnished in Section 5: Tender and Contract Forms.

24.3 Tenderers shall include the following information and documents with their Tenders:

- (a) total monetary value of similar goods supplied for each of the last five (5) years;
- (b) details of major supplies of similar types of Goods over the last five (5) years, and clients who may be contacted for further information on those contracts;
- (c) financial reports or balance sheets or profit and loss statements or auditor's reports or bank references with documents or a combination of these demonstrating the availability of liquid assets to successfully complete the contract;
- (d) authority to seek references from the Tenderer's Bankers; and
- (e) information on past (5 years) litigation in which the Tenderer has been involved or in which the Tenderer is currently involved.

24.4 Tenders submitted by a JVCA shall comply with the following requirements, and any other requirements as specified in the TDS:

- (a) the Tenderer shall include all the information listed in ITT Sub-Clause 24.3 for each JVCA Member;
- (b) the Tender shall be signed so as to be legally binding on all Members;
- (c) all Members shall be jointly and severally liable for the execution of the Contract in accordance with the Contract terms;
- (d) one of the Members will be nominated as being in charge, authorised to incur liabilities, and receive instructions for and on behalf of any and all Members of the JVCA; and
- (e) the execution of the entire Contract, including payment, shall be done exclusively with the Member in charge.

25. Tenderer:
Disqualification

25.1 The Purchaser shall disqualify a Tenderer who submits a document containing false information for purposes of qualification or misleads or makes false representations in proving its qualification requirements. If such an occurrence is proven, the Purchaser may declare such a Tenderer ineligible, either indefinitely or for a stated period of time, from participation in future procurement proceedings.

25.2 The Purchaser may disqualify a Tenderer who has a record of poor performance, such as abandoning the supply, not properly completing the contract, inordinate delays, litigation history or financial failures.

-
26. Tender: Validity
- 26.1 Tenders shall remain valid for the period specified in the TDS after the date of Tender submission prescribed by the Purchaser, pursuant to ITT Clause 30. A Tender valid for a shorter period shall reject by the Purchaser as non-responsive.
- 26.2 In exceptional circumstances, prior to the expiration of the Tender validity period, the Purchaser may solicit the Tenderers' consent to an extension of the period of validity of their Tenders. The request and the responses shall be made in writing. The Tender Security provided under ITT Clause 27, shall also be suitably extended promptly. If a Tenderer does not respond or refuses the request it shall not forfeit its Tender Security, but its Tender shall no longer be considered in the evaluation proceedings. A Tenderer agreeing to the request will not be required or permitted to modify its Tender.
27. Tender: Security
- 27.1 The Tenderer shall furnish as part of its Tender, a Tender Security in original form (Form G-6) and in the amount specified in the TDS.
- 27.2 The Tender Security shall:
- (a) at the Tenderer's option be either;
 - (i) in the form of a bank draft or pay order; or
 - (ii) in the form of an irrevocable bank guarantee (Form G-6) issued by a Scheduled Bank of Bangladesh in the format furnished in Section 5: Tender and Contract Forms;
 - (b) be payable promptly upon written demand by the Purchaser in the case of the conditions listed in ITT Sub-Clause 27.5 being invoked; and
 - (c) remain valid for a period of twenty-eight (28) days beyond the original validity period of Tenders, or beyond any period of extension subsequently requested in ITT Sub-Clause 26.2.
- 27.3 A Tender not accompanied by a valid Tender Security in accordance with ITT Sub-Clause 27.2, shall be rejected by the Purchaser as non-responsive.
- 27.4 Unsuccessful Tenderers' Tender Security will be discharged or returned within twenty-eight (28) days of the end of the Tender validity period specified in ITT Sub-Clause 26.1 and 26.2. The Tender Security of the successful Tenderer will be discharged upon the successful Tenderer's furnishing of the Performance Security pursuant to ITT Clause 50 and signing the Contract Agreement.
- 27.5 The Tender Security may be forfeited:
- (a) if a Tenderer withdraws its Tender during the period of Tender validity specified by the Tenderer on the Tender Submission Sheet, except as provided in ITT Sub-Clause 26.2; or

-
- (b) if the successful Tenderer fails to:
 - (i) accept the correction of its Tender Price pursuant to ITT Sub-Clause 39.3; or
 - (ii) furnish a Performance Security in accordance with ITT Clause 50; or
 - (iii) sign the Contract in accordance with ITT Clause 51.

27.6 The Tender Security of a JVCA shall be in the name of the JVCA that submits the Tender. If the JVCA has not been legally constituted at the time of tendering, the Tender Security shall be in the name of all intended JVCA Members as named in the letter of intent mentioned in ITT Sub-Clause 22.1(b).

28. Tender
Format and
Signing

28.1 The Tenderer shall prepare one (1) original of the documents comprising the Tender as described in ITT Sub-Clause 17.1 and clearly mark it "ORIGINAL". In addition, the Tenderer shall prepare the number of copies of the Tender, as specified in the TDS and clearly mark each of them "COPY". In the event of any discrepancy between the original and the copies, the original shall prevail.

28.2 The original and each copy of the Tender shall be typed or written in indelible ink and shall be signed by a person duly authorised to sign on behalf of the Tenderer. This authorisation shall consist of a written authorisation and shall be attached to the Tenderer Information Sheet (Form G-4). The name and position held by each person signing the authorisation must be typed or printed below the signature. All pages of the original and of each copy of the Tender, except for un-amended printed literature, shall be numbered sequentially and signed or initialled by the person signing the Tender.

28.3 Any interlineations, erasures, or overwriting shall be valid only if they are signed or initialled by the person(s) signing the Tender.

E. Tender Submission

29. Tender:
Sealing and
Marking

29.1 The Tenderer shall enclose the original in one (1) envelope and all the copies of the Tender in another envelope, duly marking the envelopes as "ORIGINAL" and "COPY." The two (2) envelopes shall then be enclosed and sealed in one (1) single outer envelope.

29.2 The inner and outer envelopes shall:

- (a) bear the name and address of the Tenderer;
- (b) be addressed to the Purchaser at the address specified in the TDS;
- (c) bear the name of the Tender and the Tender Number as specified in the TDS; and
- (d) bear a statement "DO NOT OPEN BEFORE..." the time

and date for Tender opening as specified in the TDS.

- 29.3 If all envelopes are not sealed and marked as required by ITT Sub-Clause 29.2, the Purchaser will assume no responsibility for the misplacement or premature opening of the Tender.
30. Tender: Submission Deadline
- 30.1 Tenders must be received by the Purchaser at the address specified in ITT Sub-Clause 29.2 no later than the date and time as specified in the TDS.
- 30.2 Tenders may be hand delivered, posted by registered mail or sent by courier. The Purchaser shall, on request, provide the Tenderer with a receipt showing the date and time when its Tender was received.
- 30.3 The Purchaser may, at its discretion, extend the deadline for the submission of Tenders by amending the Tender Document in accordance with ITT Clause 10, in which case all rights and obligations of the Purchaser and Tenderers previously subject to the deadline shall thereafter be subject to the new deadline as extended.
31. Tender: Submitted Late
- 31.1 Any Tender received by the Purchaser after the deadline for submission of Tenders in accordance with ITT Clause 30 shall be declared late, will be rejected, and returned unopened to the Tenderer.
32. Tender: Modification, Substitution or Withdrawal
- 32.1 A Tenderer may modify, substitute or withdraw its Tender after it has been submitted by sending a written notice, duly signed by the same authorised representative, and shall include a copy of the authorisation in accordance with ITT Sub-Clause 28.2, (except that no copies of the withdrawal notice are required). The corresponding substitution or modification of the Tender must accompany the respective written notice. The written notice must be:
- (a) submitted in accordance with ITT Clauses 28 and 29 (except that withdrawal notices do not require copies), and in addition, the respective envelopes shall be clearly marked "MODIFICATION" "SUBSTITUTION," OR "WITHDRAWAL," and
 - (b) received by the Purchaser prior to the deadline prescribed for submission of Tenders, in accordance with ITT Clause 30.
- 32.2 Tenders requested to be withdrawn in accordance with ITT Sub-Clause 32.1 shall be returned unopened to the Tenderers, only after the Tender opening.
- 32.3 No Tender shall be modified, substituted or withdrawn after the deadline for submission of Tenders specified in ITT Clause 30.

F. Tender Opening and Evaluation

33. Tender: Opening
- 33.1 The Purchaser shall open the Tenders in public, including modifications or substitutions made pursuant to ITT Clause 32, at the time, on the date, and at the one place specified in the TDS. Tenders for which an acceptable notice of withdrawal has been submitted pursuant to ITT Clause 32 shall not be opened. Tenderers or their authorised representatives shall be allowed to attend and witness the opening of Tenders, and shall sign a register evidencing their attendance.
- 33.2 The name of the Tenderer, Tender modifications, substitutions or withdrawals, total amount of each Tender, number of corrections, discounts, and the presence or absence of a Tender Security, any alternatives if so permitted, and such other details as the Purchaser, at its discretion, may consider appropriate, shall be read out aloud and recorded. Only those discounts and alternative offers read out at the Tender opening shall be considered for evaluation. All pages of the original of the Tenders, except for un-amended printed literature, will be initialled by a minimum of three (3) members of the Purchaser's Tender Opening Committee.
- 33.3 Minutes of the Tender opening shall be made by the Purchaser and furnished to any Tenderer upon receipt of a written request. The minutes shall include, as a minimum: the name of the Tenderer and whether there is a withdrawal, substitution or modification, the Tender Price, per lot if applicable, including any discounts and alternative offers, and the presence or absence of a Tender Security, if one was required.
- 33.4 Tenders not opened and read out at the Tender opening shall not be considered, irrespective of the circumstances, and shall be returned unopened to the Tenderer.
- 33.5 No Tender shall be rejected at the Tender opening, except for late Tenders, which shall be returned unopened to the Tenderer pursuant to ITT Clause 31.
34. Tender: Confidentiality
- 34.1 After the opening of Tenders, information relating to the examination, clarification, and evaluation of Tenders and recommendations for award shall not be disclosed to Tenderers or other persons not officially concerned with the evaluation process until after the award of the Contract is announced.
35. Tender: Clarification
- 35.1 The Purchaser may ask Tenderers for clarification of their Tenders in order to facilitate the examination and evaluation of Tenders. The request for clarification and the response shall be in writing, and any changes in the prices or substance of the Tender shall not be sought, offered or permitted, except to confirm the correction of arithmetical errors discovered by the Purchaser in the evaluation of the Tenders, in accordance with ITT Clause 39.

-
36. Tenderer: Contacting the Purchaser
- 36.1 Following the opening of the Tenders and until the Contract is signed no Tenderer shall make any unsolicited communication to the Purchaser or try in any way to influence the Purchaser's examination and evaluation of the Tenders.
- 36.2 Any effort by a Tenderer to influence the Purchaser in its decisions on the examination, evaluation, comparison, and post-qualification of the Tenders or Contract award may result in the rejection of its Tender.
- 36.3 Notwithstanding ITT Sub Clause 36.1, from the time of Tender opening to the time of Contract award, if any Tenderer wishes to contact the Purchaser on any matter related to the tendering process, it should do so in writing.
37. Tender: Responsive ness
- 37.1 The Purchaser's determination of a Tender's responsiveness is to be based on the contents of the Tender itself without recourse to extrinsic evidence.
- 37.2 A substantially responsive Tender is one that conforms in all respects to the requirements of the Tender Document without material deviation, reservation, or omission. A material deviation, reservation, or omission is one that:
- (a) affects in any substantial way the scope, quality, or performance of the Goods and Related Services specified in the Contract; or
 - (b) limits in any substantial way or is inconsistent with the Tender Document, the Purchaser's rights or the Tenderer's obligations under the Contract; or
 - (c) if rectified would unfairly affect the competitive position of other Tenderers presenting substantially responsive Tenders.
- 37.3 If a Tender is not substantially responsive to the Tender Document it shall be rejected by the Purchaser and shall not subsequently be made responsive by the Tenderer by correction of the material deviation, reservation or omission.
- 37.4 There shall be no requirement as to the minimum number of responsive Tenders.
38. Tender: Non-conformities, Errors, and Omissions
- 38.1 The Purchaser may regard a Tender as responsive even if it contains minor deviations that do not materially alter or depart from the characteristics, terms, conditions and other requirement set forth in Tender Document or if it contains errors or oversights that are capable of being corrected without affecting the substance of the Tender.
- 38.2 Provided that a Tender is substantially responsive, the Purchaser may request that the Tenderer submits the necessary information or documentation, within a reasonable period of time, to rectify nonmaterial nonconformities or omissions in the Tender related to documentation requirements. Such omission shall not be related to

-
- any aspect of the price of the Tender. Failure by the Tenderer to comply with the request may result in the rejection of its Tender.
39. Tender: Correction of Arithmetical Errors
- 39.1 Provided that the Tender is substantially responsive, the Purchaser shall correct arithmetical errors on the following basis:
- (a) if there is a discrepancy between the unit price and the total price that is obtained by multiplying the unit price and quantity, the unit price shall prevail and the total price shall be corrected, unless, in the opinion of the Purchaser, there is an obvious misplacement of the decimal point in the unit price, in which case the total price as quoted shall govern and the unit price shall be corrected;
 - (b) if there is an error in a total corresponding to the addition or subtraction of subtotals, the subtotals shall prevail and the total shall be corrected; and
 - (c) if there is a discrepancy between words and figures, the amount in words shall prevail, unless the amount expressed in words is related to an arithmetical error, in which case the amount in figures shall prevail subject to (a) and (b) above.
- 39.2 Any arithmetical error or other discrepancy, as stated in ITT Sub-Clause 39.1, is found it shall be immediately notified to the concerned Tenderer.
- 39.3 Any Tenderer that does not accept the correction of errors as determined by the application of ITT Sub-Clause 39.1, its Tender shall be disqualified and its Tender Security may be forfeited.
40. Tender: Preliminary Examination
- 40.1 The Purchaser shall firstly examine the Tenders to confirm that all documentation requested in ITT Clause 17 has been provided, and to determine the completeness of each document submitted.
- 40.2 The Purchaser shall assess whether the Tenderer's Qualifications as per Section C are substantially met. Any negative determination by the Purchaser will result in rejecting the Tender as non-responsive without the need for further evaluation as per ITT Clauses 41 and 42.
41. Tender: Technical Evaluation
- 41.1 The Purchaser shall secondly examine the Tender to confirm that all terms and conditions specified in the GCC and the PCC have been accepted by the Tenderer without any material deviation or reservation.
- 41.2 The Purchaser shall evaluate the technical aspects of the Tender submitted in accordance with ITT Clause 23, to confirm that all requirements specified in Section 7: Technical Specifications, have been met without any material deviation or reservation.
- 41.3 If, after the examination of the terms and conditions and the technical aspects of the Tender, the Purchaser determines that the Tender is not substantially responsive in accordance with ITT Clause 37, it shall reject the Tender.
-

42. Tender:
Financial
Evaluation

42.1 The Purchaser shall thirdly evaluate each Tender that has been determined, up to this stage of the evaluation, to be substantially responsive.

42.2 To evaluate a Tender, the Purchaser shall consider the following:

- (a) the Tender price as quoted in accordance with ITT Clauses 18 and 20, excluding local taxes (VAT and other taxes) which will be payable on the goods if contract is awarded);
- (b) price adjustment for correction of arithmetical errors pursuant to ITT Sub-Clause 39.1;
- (c) the applicable economic factors of evaluation set out in ITT Sub-Clause 42.3.

42.3 The Purchaser's economic evaluation of a Tender will take into account, in addition to the delivered price offered in accordance with ITT Sub-Clause 18.1, one or more of the factors affecting the economic value of the Tender from the list below, as specified in the TDS, and as quantified in ITT Sub-Clause 42.5:

- (a) the delivery schedule offered in the Tender; and
- (b) the cost of components, mandatory spare parts, and service;
- (c) the availability in Bangladesh of spare parts and after-sales services for the equipment offered in the Tender;
- (d) the projected operating and maintenance costs during the anticipated life-cycle of the equipment;
- (e) the performance and productivity of the equipment offered; or
- (f) any other specific criteria as specified in Section 7: Technical Specifications.

42.4 For those factors specified in ITT Sub Clause 42.3 which are selected to be considered in the evaluation of the Tenders, one or more of the following quantification methods shall be applied, as specified in the TDS.

(a) *Delivery schedule:*

- (i) The goods covered under the IFT are required to be delivered at the time specified in Section 6: Schedule of Requirements. Treating the Tender with the earliest delivery as the base, a delivery 'adjustment' will be calculated for other Tenders for the purpose of evaluation, by applying a percentage, as specified in the TDS, of the Tender price for each week of delay beyond the base, and this will be added to the Tender price for evaluation. No credit shall be given to early delivery.

or

-
- (ii) The goods covered under the IFT are required to be delivered within an acceptable range of weeks as specified in Section 6: Schedule of Requirements. No credit shall be allowed to earlier deliveries, and Tenders offering delivery beyond this range shall be treated as non-responsive. Within this acceptable range, an adjustment per week, as specified in the TDS, will be added, for the purpose of evaluation, to the Tender price of Tenders offering deliveries later than the earliest delivery period specified in Section 6: Schedule of Requirements.

or

- (iii) The goods covered under the IFT are required to be delivered in partial shipments, as specified in Section 6: Schedule of Requirements. Tenders offering deliveries later than the specified deliveries will be adjusted for the purpose of evaluation by adding to the Tender price a factor equal to a percentage, as specified in the TDS, of the Tender price per week of variation from the specified delivery schedule.

(b) *Cost of components and mandatory spare parts:*

The schedule of items and quantities of major assemblies, components, and selected spare parts, likely to be required during the initial period of operation specified in the TDS is annexed to Section 7: Technical Specifications. The total cost of these items, at the unit prices quoted in each Tender, will be added to the Tender price.

(c) *Spare parts and after sales service facilities in Bangladesh:*

The cost to the Purchaser of establishing the minimum service facilities and parts inventories, as outlined in the TDS or Section 7: Technical Specifications, if quoted separately, shall be added to the Tender price.

(d) *Projected operating and maintenance costs:*

Operating and maintenance costs of the goods will be evaluated in accordance with the criteria specified in the TDS or in Section 7: Technical Specifications.

(e) *Performance and productivity of the equipment:*

- (i) Tenderers shall state the guaranteed performance or efficiency of their equipment offered in response to Section 7: Technical Specifications. For each drop in the performance or efficiency below the norm of 100, an adjustment for an amount specified in the TDS will be added to the Tender price for the purpose of evaluation, representing the capitalized cost of additional operating costs over the life of the plant, using the methodology specified in Section 7: Technical Specifications.

or

- (i) Equipment offered shall have a minimum productivity specified under the relevant provision in Section 7: Technical Specifications, to be considered responsive. Evaluation shall be based on the cost per unit of the actual productivity of goods offered in the Tender, and adjustment will be added to the Tender prices for the purpose of evaluation, using the methodology specified in Section 7: Technical Specifications.

(f) *Specific additional criteria:*

Other specific additional criteria to be considered in the evaluation and the evaluation method to be used for such criteria shall be as specified in the TDS and/or Section 7: Technical Specifications.

42.5 If so indicated in the TDS (ITT Sub-Clause 20.3), the Tender Document shall allow Tenderers to quote separate prices for one or more lots, and shall allow the Purchaser to award one or multiple lots to more than one Tenderer following the methodology specified in ITT Sub-Clause 42.6.

42.6 To determine the lowest evaluated lot, or combination of lots, the Purchaser shall:

- (a) evaluate only the lot or lots which comply with the requirements specified in ITT Sub-Clause 20.3;
- (b) take into account:
 - (i) the experience and resources sufficient to meet the aggregate of the qualifying criteria for the individual lots;
 - (ii) the lowest-evaluated Tender for each lot calculated in accordance with the requirements of Evaluation Criteria;
 - (iii) the price reduction per lot or combination of lots and the methodology for their application as offered by the Tenderer in its Tender; and
 - (iv) the Contract award sequence that provides the optimum economic combination, taking into account any limitations due to constraints in supply or execution capacity determined in accordance with the post-qualification criteria under ITT Clause 45.

43. Tender: No Negotiation

43.1 No negotiation shall be held with the lowest or any other Tenderer.

43.2 A Tenderer shall not be required, as a condition for award, to undertake responsibilities not stipulated in the Tender Document, to change its price or otherwise to modify its Tender.

44. Tender: Comparison

44.1 The Purchaser shall compare all substantially responsive Tenders to determine the lowest-evaluated Tender, in accordance with ITT Clause 42.

-
45. Tenderer: Post-qualification
- 45.1 The Purchaser shall determine to its satisfaction whether the Tenderer that is selected as having submitted the lowest evaluated and substantially responsive Tender is qualified to perform the Contract satisfactorily.
- 45.2 The determination shall be based upon an examination of the documentary evidence of the Tenderer's qualifications submitted by the Tenderer, pursuant to ITT Clause 24, to clarifications in accordance with ITT Clause 35 and the qualification criteria indicated in ITT Clauses 11, 12 and 13. Factors not included therein shall not be used in the evaluation of the Tenderer's qualification.
- 45.3 An affirmative determination shall be a prerequisite for award of the Contract to the Tenderer. A negative determination shall result in rejection of the Tenderer's Tender, in which event the Purchaser shall proceed to the next lowest evaluated Tender to make a similar determination of that Tenderer's capabilities to perform satisfactorily.
46. Tenders: Purchaser's Right to Accept or to Reject Any or All
- 46.1 The Purchaser reserves the right to accept any Tender, to annul the Tender process, or to reject any or all Tenders, at any time prior to contract award, without thereby incurring any liability to the affected Tenderers, or any obligation to inform Tenderers of the grounds for the Purchaser's actions..

G. Contract Award

47. Award Criteria
- 47.1 The Purchaser shall award the Contract to the Tenderer whose offer is substantially responsive to the Tender Document and that has been determined to be the lowest evaluated Tender, provided further that the Tenderer is determined to be qualified to perform the Contract satisfactorily.
48. Purchaser's Right to Vary Quantities
- 48.1 The Purchaser reserves the right at the time of Contract Award to increase or decrease the quantity, per item, of Goods and Related Services originally specified in Section 6: Schedule of Requirements, provided this does not exceed the percentages indicated in the TDS, and without any change in the unit prices or other terms and conditions of the Tender and the Tender Document.
49. Notification of Award
- 49.1 Prior to the expiration of the period of Tender validity, the Purchaser shall notify the successful Tenderer, in writing, that its Tender has been accepted.
- 49.2 Until a formal Contract is prepared and executed, the Notification of Award shall constitute a binding Contract.
- 49.3 The Notification of Award shall state the value of the proposed Contract, the amount of the Performance Security, the time within which the Performance Security shall be submitted and the time within which the Contract shall be signed.
50. Performance Security
- 50.1 Within fourteen (14) days of the receipt of Notification of Award from the Purchaser, the successful Tenderer shall furnish Performance

Security for the due performance of the Contract in the amount specified in the TDS, using for that purpose the Performance Security Form (Form G-8) furnished in Section 5: Tender and Contract Forms.

- 50.2 The Performance Security shall be valid until a date twenty-eight (28) days after the date of completion of the Supplier's performance obligations under the Contract, including any warranty obligations.
- 50.3 The proceeds of the Performance Security shall be payable to the Purchaser unconditionally upon first written demand as compensation for any loss resulting from the Supplier's failure to complete its obligations under the Contract.
51. Contract: Signing
- 51.1 At the same time as the Purchaser issues the Notification of Award, the Purchaser shall send the Contract Agreement and all documents forming the Contract, to the successful Tenderer.
- 51.2 Within twenty-one (21) days of receipt of the Contract Agreement, the successful Tenderer shall sign, date and return it to the Purchaser.
- 51.3 Failure of the successful Tenderer to submit the Performance Security pursuant to ITT Clause 50 or sign the Contract pursuant to ITT Sub-Clause 51.2 shall constitute sufficient grounds for the annulment of the award and forfeiture of the Tender Security. In that event, the Purchaser may award the Contract to the next lowest evaluated responsive Tenderer at their quoted price (corrected for arithmetical errors), who is assessed by the Purchaser to be qualified to perform the Contract satisfactorily.
- 51.4 Immediately upon receipt of the signed Contract Agreement and Performance Security from the successful Tenderer, the Purchaser shall discharge and return the successful Tenderer's Tender Security.
52. Advising Unsuccessful Tenderers
- 52.1 Upon the successful Tenderer furnishing Performance Security pursuant to ITT Clause 50, and signing the Contract pursuant to ITT Sub-Clause 51.2, the Purchaser shall also notify all other Tenderers that their Tenders have been unsuccessful.
- 52.2 The Purchaser shall promptly respond in writing to any unsuccessful Tenderer who, after notification in accordance with ITT Sub-Clause 52.1, requests in writing for the Purchaser to communicate the grounds on which its Tender was not selected.
53. Tenderer: Right to Complain
- 53.1 Any Tenderer has the right to complain if it has suffered or may suffer loss or damage due to a breach of a duty imposed on the Purchaser by the Public Procurement Regulations 2008 (PPR).
- 53.2 The Complaint shall firstly be processed through an administrative review following the procedures set out in Regulation 51 of the PPR. The place and address for the first step in the submission of complaints to the Administrative Authority is provided in the TDS.
- 53.3 If not satisfied with the outcome of the administrative review, the Tenderer may complain to the Review Panel pursuant to Regulation 53 of the PPR.

Section 2. Tender Data Sheet

ITT Clause	Amendments of, and Supplements to, Clauses in the Instruction to Tenderers
A. General	
ITT 1.1	The Purchaser is Director (Procurement), BTCL The Name of the Tender is: Supply, Installation, Testing and Commissioning of Video conferencing system for District, Divisional and Central Administrations
ITT 2.1	The source of public fund is GoB.
ITT 2.3	The name of the Development Partner is none.
ITT 4.1	Tenderers from the following countries are not eligible: Israel
ITT 5.1	Goods and Related Services from the following counties are not eligible: Israel
B. Tender Document	
ITT 7.2	The following are authorised agents of the Purchaser for the purpose of providing the Tender Document: None
ITT 8.1	For <u>Clarification of Tender purposes</u> only, the Purchaser's address is: Attention: Deputy Director (Local Procurement) Address: Director (Procurement) Bangladesh Telecommunications Company Limited Sher-E-Banglanagar Telephone Annex Building (2 nd floor) Sher-E-Banglanagar, Dhaka. Telephone: 8150500 Facsimile number: 8150511 Electronic mail address: ddlclpct@btcl.net.bd
ITT 9.1	A Pre-Tender meeting shall not be held.

C. Qualification Criteria	
ITT 12.1(a)	<p>The Tenderer shall have a minimum three year of overall experience as on the date of submission of the tender in supply and installation of Telecom/Datacom/Video conferencing solution equipment. To this effect, tenderer must submit proper evidence(s) from the relevant authorities.</p> <p>Whatever written in different clauses of ITT, rule 54 of PPR 2008 will be applicable for JVCA.</p>
ITT 12.1(b)	<p>The Tenderer shall have at least one successful completion record of contract for supply and installation of Telecom/Datacom/ Video conferencing solution equipment having a minimum contract value of Tk. 1 (one) crore over a period of last five years.</p> <p>To this effect, tenderer must submit proper evidence(s) in the form of Certificate from the relevant purchaser. Evidence must contain full details of the Contract such as project name, contract number & price, completion date, name and designation of the person who signed the certificate.</p>
ITT 12.1(c)	<p>The minimum production capacity or availability of equipment is/ are: None</p>
ITT 13.1(a)	<p>The minimum supply value of goods under a single contract in the last five years is Tk. 1,00,00,000.00 (One Crore Only)</p>
ITT 13.1(b)	<p>The minimum amount of liquid asset or working capital or credit facility from a Scheduled Bank is Tk. 8,00,00,000.00 (Eight Crore Only).</p>
D. Preparation of Tender	
ITT 16.1	<p>The Tender, as well as all correspondence and documents relating to the Tender shall be written in the Bangla/English language.</p>
ITT 17.1(j)	<p>The Tenderer shall submit with its Tender the following additional documents:</p> <ol style="list-style-type: none"> 1. Tender document purchase receipt. 2. Signed/initialled and stamped in each page of the purchased tender document by the authorised signatory. 3. Technical Documents/Brochures, catalogues etc. of all the proposed equipment. 4. "Schedule of Compliance" stating compliance of all clauses and sub clauses and Annexure of Section-7 of the Tender Document. 5. Guarantee of spares of offered video conferencing system equipment for at least 5 (five) years from the date of issuance of Provisional Acceptance Certificate (PAC) as per format given in Annex-1, Section-7.

	<p>6. At least four (4) User Certificates from at least three countries, excluding the country of origin of the manufacturer of the Video Conferencing system. Among those, two user certificates must be from the users in Bangladesh. Each certificate must demonstrate that the user is using the video conferencing system of the offered manufacturer satisfactorily for at least two years.</p> <p><i>If any bidder does not submit any or many of the documents mentioned in serial 1, 2 and 3 above, TEC shall take decision which deems fit. If any bidder does not submit any or many of the documents mentioned in serial 4, 5 and 6 above, the bid will be rejected as “Non-Responsive” If the bidder submits user certificates but the certificates do not meet the requirements, the bid will also be rejected as “Non-Responsive.”</i></p>
ITT 19.1	Alternative Tenders will not be permitted.
ITT 20.3 & ITT 42.5	Tenders are being invited for a single lot.
ITT 20.5 (c)	The final destinations of the goods and related services are all the district head quarters of Bangladesh including the capital city.
ITT 20.5 (d)	The Tenderer shall submit prices for the following incidental services: Installation, Testing & Commissioning of the equipment and other services as specified in Section-7.
ITT 20.7	The prices quoted by the Tenderer shall be fixed for the duration of the Contract.
ITT 22.2	<p>A Manufacturer’s Authorisation Letter is required for the following products preferably in the format of “Form G-5”. However, the bidder may submit the authorization in Manufacturer’s own format provided that the authorization letter is valid for at least up to tender validity date and contains warranty issue.</p> <p>a. Video Conferencing Core Equipment</p> <p>b. Offered Central Router, Type-I and Type-II LAN Switches</p> <p>If the bid is not accompanied with the authorization letter(s), the bid will be rejected as “Non-Responsive”.</p>
ITT 26.1	The Tender validity period shall be 120 (One hundred and twenty) days.
ITT 27.1	The amount of the Tender Security shall be Tk. 35,00,000.00 (Thirty Five Lac only)
ITT 28.1	In addition to the original of the Tender, 1 (one) more “COPY” with a CD-ROM copy shall be submitted.

E. Submission of Tender	
ITT 29.2(b)	<p>For <u>Tender submission purposes</u> only, the Purchaser's address is:</p> <p>Attention:</p> <p>Address:</p> <p>Director (Procurement) Bangladesh Telecommunications Company Limited Sher-E-Banglanagar Telephone Annex Building (2nd floor) Sher-E-Banglanagar, Dhaka. Telephone: 8150500 Facsimile number: 8150511 Electronic mail address: ddclpct@btcl.net.bd</p> <p>The deadline for submission of Tenders is as mentioned in the tender notice.</p>
ITT 29.2(c)	<p>The inner and outer envelope shall bear the following additional identification marks: (1) Mark "Inner" for Inner Envelop and "Outer" for outer envelop. On each envelop, bidder shall write at least the Tender Name & Number with Bidder's Name & Address.</p>
F. Opening and Evaluation of Tenders	
ITT 33.1	<p>The Tender opening shall take place at:</p> <p>Address:</p> <p>Office of the Director (Procurement) Bangladesh Telecommunications Company Limited Sher-E-Banglanagar Telephone Annex Building (2nd floor) Sher-E-Banglanagar, Dhaka.</p> <p>On Time & Date: As mentioned in the tender notice.</p>
ITT 42.4	<p>The applicable economic factors for evaluation shall be as follows: Not Applicable.</p>
ITT 42.4(a)	<p>The following quantification methods shall be applied.</p> <p><u>Delivery schedule.</u></p> <p>Option (i), or Option (ii), or Option (iii)</p> <p>Supply, Installation, Testing & Commissioning must be completed within 20 (twenty) weeks and No adjustment is allowed for any late or advance delivery offer during evaluation. The time starts from the date of signing of contract.</p> <p>adjustment expressed as a percentage, Not Applicable</p> <p>adjustment expressed a percentage, Not Applicable</p> <p>adjustment expressed as a percentage Not Applicable</p>
ITT 42.4(b)	<p>Cost of components and mandatory spare parts: Not Applicable</p>

ITT 42.4(c)	Spare parts and after-sales service facilities in Bangladesh: The Bidder shall give after sale services guarantee for at least 5 (five) years from the date of issuance of PAC.
ITT 42.4(d)	Projected operating and maintenance costs: None
ITT 42.4(e)	Performance and productivity of equipment. None
G. Award of Contract	
ITT 48.1	The maximum percentage by which quantities per item may be increased/decreased is 15% [fifteen <i>percent</i>].
ITT 50.1	The amount of Performance Security shall be ten [10] percent of the Contract Price.
ITT 53.2	<p>The name and address of the office where complaints to the Procuring Entity under Regulation 51 are to be submitted is:</p> <p>Managing Director Bangladesh Telecommunications Company Limited Telejogajoj Bhaban 37/E Eskaton Garden, Dhaka-1000</p> <p>Note: The Bidder shall remember that PPR-2008 and its subsequent amendments shall be followed in the whole tendering process.</p>

Section 3. General Conditions of Contract

1. Definitions 1.1 The following words and expressions shall have the meaning hereby assigned to them. Boldface type is used to identify the defined term:
- (a) **Completion Schedule** means the fulfilment of the Related Services by the Supplier in accordance with the terms and conditions set forth in the Contract;
 - (b) **Contract Agreement** means the Agreement entered into between the Purchaser and the Supplier, together with the Contract Documents referred to therein, including all attachments, appendices, and all documents incorporated by reference therein;
 - (c) **Contract Documents** means the documents listed in the Contract Agreement, including any amendments thereto;
 - (d) **Contract Price** means the price payable to the Supplier as specified in the Contract Agreement, subject to such additions and adjustments thereto or deductions therefrom, as may be made pursuant to the Contract;
 - (e) **Day** means calendar day;
 - (f) **Delivery** means the transfer of ownership of the Goods from the Supplier to the Purchaser in accordance with the terms and conditions set forth in the Contract;
 - (g) **GCC** mean the General Conditions of Contract;
 - (h) **Goods** means all of the commodities, raw materials, machineries and equipments, products and/or other materials in solid, liquid or gaseous form that the Supplier is required to supply to the Purchaser under the Contract, as specified in the PCC;
 - (i) **Government** means the Government of the People's Republic of Bangladesh;
 - (j) **Purchaser** means the entity purchasing the Goods and Related Services, as specified in the PCC;
 - (k) **Related Services** means the services incidental to the supply of the goods, such as insurance, installation, training and initial maintenance and other similar obligations of the Supplier under the Contract;
 - (l) **PCC** means the Particular Conditions of Contract;
 - (m) **Subcontractor** means any natural person, private or government entity, or a combination of the above, including its legal successors or permitted assigns, who has a Contract with the Supplier to carry out a part of the supply in the Contract, or

a part of the Related Services of the Contract;

(n) **Supplier** means the natural person, private or government entity, or a combination of the above, whose Tender to perform the Contract has been accepted by the Purchaser and is named as such in the PCC and the Contract Agreement, and includes the legal successors or permitted assigns of the Supplier;

(o) **Writing** means any hand-written, type-written, or printed communication including telex, cable and facsimile transmission

2. Contract Documents 2.1 Subject to the order of precedence set forth in the GCC Sub-Clause 5.1, all documents forming the Contract (and all parts thereof) are intended to be correlative, complementary, and mutually explanatory.

3. Corrupt, Fraudulent, Collusive or Coercive Practices 3.1 The Government requires that Purchasers, as well as Suppliers, shall observe the highest standard of ethics during the implementation of procurement proceedings and the execution of contracts under public funds.

3.2 In pursuance of this requirement, the Purchaser shall:

(a) exclude the Supplier from participation in the procurement proceedings concerned or reject a proposal for award; and

(b) declare a Supplier ineligible, either indefinitely or for a stated period of time, from participation in procurement proceedings under public funds;

if it at any time determines that the Supplier has engaged in corrupt, fraudulent, collusive or coercive practices in competing for, or in executing, a contract under public funds.

3.3 Should any corrupt, fraudulent, collusive or coercive practice of any kind referred to in GCC Sub-Clause 3.4 hereunder come to the knowledge of the Purchaser, it shall, in the first place, allow the Supplier to provide an explanation and shall, take actions as stated in GCC Sub-Clause 3.2 and GCC Sub-Clause 38.1(c) only when a satisfactory explanation is not received. Such exclusion and the reasons thereof shall be recorded in the record of the procurement proceedings and promptly communicated to the Supplier concerned. Any communications between the Supplier and the Purchaser related to matters of alleged corrupt, fraudulent, collusive or coercive practices shall be in writing.

3.4 The Government defines, for the purposes of this provision, the terms set forth below as follows:

(a) *“corrupt practice”* means offering, giving, or promising to give, directly or indirectly, to any officer or employee of a Procuring Entity or other governmental/private authority or individual a gratuity in any form, an employment or any other thing or

service of value, as an inducement with respect to an act or decision of, or method followed by, a Procuring Entity in connection with the procurement proceeding;

(b) “*fraudulent practice*” means a misrepresentation or omission of facts in order to influence a procurement proceeding or the execution of a contract to the detriment of the Purchaser;

(c) “*collusive practice*” means a scheme or arrangement among two or more Tenderers with or without the knowledge of the Purchaser (prior to or after Tender submission) designed to establish Tender prices at artificial, non-competitive levels and to deprive the Purchaser of the benefits of free, open and genuine competition; and

(d) “*coercive practice*” means harming or threatening to harm, directly or indirectly, persons or their property to influence the procurement proceedings or affect the execution of a contract.

3.5 The Supplier shall permit the Purchaser to inspect the Supplier’s accounts and records and other documents relating to the submission of the Tender and Contract performance.

4. Interpretation 4.1 In interpreting the GCC, singular also means plural, male also means female or neuter, and the other way around. Headings in the GCC shall not be deemed part thereof or be taken into consideration in the interpretation or construction thereof or of the Contract. Words have their normal meaning under the English language unless specifically defined.

4.2 Entire Agreement

(a) The Contract constitutes the entire agreement between the Purchaser and the Supplier and supersedes all communications, negotiations and agreements (whether written or oral) of parties with respect thereto made prior to the date of Contract Agreement.

4.1 Amendment

(a) No amendment or other variation of the Contract shall be valid unless it is in writing, is dated, expressly refers to the Contract, and is signed by a duly authorised representative of each party thereto.

4.4 Non-waiver

(a) Subject to GCC Sub-Clause 4.4(b), no relaxation, forbearance, delay, or indulgence by either party in enforcing any of the terms and conditions of the Contract or the granting of time by either party to the other shall prejudice, affect, or restrict the rights of that party under the Contract, neither shall any waiver by either party of any breach of Contract operate as waiver of any subsequent or continuing breach of Contract.

-
- (b) Any waiver of a party's rights, powers, or remedies under the Contract must be in writing, dated, and signed by an authorised representative of the party granting such waiver, and must specify the right and the extent to which it is being waived.
- 4.5 Severability
- (a) If any provision or condition of the Contract is prohibited or rendered invalid or unenforceable, such prohibition, invalidity or unenforceability shall not affect the validity or enforceability of any other provisions and conditions of the Contract.
- 4.6 Partial Supply
- (a) If partial supply is specified in the Schedule of Requirements, references in the GCC to the Supply and to the Delivery Date shall apply to any portion of the Supply (other than references to the Completion Date for the whole of the Supply).
5. Documents Forming the Contract and Priority of Documents
- 5.1 The following documents forming the Contract shall be interpreted in the following order of priority:
- (a) the signed Contract Agreement;
 - (b) the letter of Notification of Award
 - (c) the completed Tender Submission Sheet as submitted by the Tenderer;
 - (d) the completed Price Schedules as submitted by the Tenderer;
 - (e) the Particular Conditions of Contract;
 - (f) the General Conditions of Contract;
 - (g) the Schedule of Requirements;
 - (h) the Technical Specifications;
 - (i) the Drawings, and;
 - (j) any other document listed in the PCC as forming part of the Contract.
6. Eligibility
- 6.1 The Supplier and its Sub-Contractors shall have the nationality of a country other than those specified in the PCC.
- 6.2 All Goods and Related Services supplied under the Contract shall have their origin in the countries except those specified in the PCC.
7. Governing Language
- 7.1 The Contract as well as all correspondence and documents relating to the Contract exchanged by the Supplier and the Purchaser shall be written in English, unless otherwise stated in the PCC. Supporting documents and printed literature that are part of the Contract may be in another language provided they are accompanied by an accurate translation of the relevant passages in English, in which case, for purposes of interpretation of the Contract, this translation shall govern.
- 7.2 The Supplier shall bear all costs of translation to the governing language and all risks of the accuracy of such translation.
8. Governing
- 8.1 The Contract shall be governed by and interpreted in accordance with

Law		the laws of the People’s Republic of Bangladesh.
9. Gratuities / Agency fees	9.1	No fees, gratuities, rebates, gifts, commissions or other payments, other than those shown in the Tender or the contract, shall be given or received in connection with the procurement process or in the contract execution.
10. Joint Venture, Consortium or Association (JVCA)	10.1	If the Supplier is a joint venture, consortium, or association, all of the parties shall be jointly and severally liable to the Purchaser for the fulfilment of the provisions of the Contract and shall designate one party to act as a leader with authority to bind the joint venture, consortium, or association. The composition or the constitution of the joint venture, consortium, or association shall not be altered without the prior consent of the Purchaser.
11. Confidential Information	11.1	The Purchaser and the Supplier shall keep confidential and shall not, without the written consent of the other party hereto, divulge to any third party any documents, data, or other information furnished directly or indirectly by the other party hereto in connection with the Contract, whether such information has been furnished prior to, during or following completion or termination of the Contract. Notwithstanding the above, the Supplier may furnish to its Subcontractor such documents, data, and other information it receives from the Purchaser to the extent required for the Subcontractor to perform its work under the Contract, in which event the Supplier shall obtain from such Subcontractor an undertaking of confidentiality similar to that imposed on the Supplier under GCC Clause 11.
	11.2	The Purchaser shall not use such documents, data, and other information received from the Supplier for any purposes unrelated to the contract. Similarly, the Supplier shall not use such documents, data, and other information received from the Purchaser for any purpose other than the design, procurement, or other work and services required for the performance of the Contract.
	11.3	The obligation of a party under GCC Sub-Clauses 11.1 and 11.2 above, however, shall not apply to information that: <ul style="list-style-type: none"> (a) the Purchaser or Supplier needs to share with institutions participating in the financing of the Contract; (b) now or hereafter enters the public domain through no fault of that party; (c) can be proven to have been possessed by that party at the time of disclosure and which was not previously obtained, directly or indirectly, from the other party; or (d) otherwise lawfully becomes available to that party from a third party that has no obligation of confidentiality.
	11.4	The above provisions of GCC Clause 11 shall not in any way modify any undertaking of confidentiality given by either of the parties hereto prior to the date of the Contract in respect of the Supply or any part thereof.

-
- 11.5 The provisions of GCC Clause 11 shall survive completion or termination, for whatever reason, of the Contract.
12. Communications and Notices
- 12.1 Communications between Parties (notice, request or consent required or permitted to be given or made by one party to the other) pursuant to the Contract shall be in writing to the addresses specified in the PCC.
- 12.2 A notice shall be effective when delivered or on the notice's effective date, whichever is later.
- 12.3 A Party may change its address for notice hereunder by giving the other Party notice of such change to the address.
13. Patent and Intellectual Property Rights
- 13.1 The Supplier shall, subject to the Purchaser's compliance with GCC Sub-Clause 13.2, indemnify and hold harmless the Purchaser and its employees and officers from and against any and all suits, actions or administrative proceedings, claims, demands, losses, damages, costs, and expenses of any nature, including attorney's fees and expenses, which the Purchaser may suffer as a result of any infringement or alleged infringement of any patent, utility model, registered design, trademark, copyright, or other intellectual property rights registered or otherwise existing at the date of the Contract by reason of:
- (a) the installation of the Goods by the Supplier or the use of the Goods in Bangladesh; and
 - (b) the sale in any country of the products produced by the Goods.
- Such indemnity shall not cover any use of the Goods or any part thereof other than for the purpose indicated by or to be reasonably inferred from the Contract, neither any infringement resulting from the use of the Goods or any part thereof, or any products produced thereby in association or combination with any other equipment, plant, or materials not supplied by the Supplier, pursuant to the Contract.
- 13.2 If any proceedings are brought or any claim is made against the Purchaser arising out of the matters referred to in GCC Sub-Clause 13.1, the Purchaser shall promptly give the Supplier a notice thereof, and the Supplier may at its own expense and in the Purchaser's name conduct such proceedings or claim and any negotiations for the settlement of any such proceedings or claim.
- 13.3 If the Supplier fails to notify the Purchaser within twenty-eight (28) days after receipt of such notice that it intends to conduct any such proceedings or claim, then the Purchaser shall be free to conduct the same on its own behalf.
- 13.4 The Purchaser shall, at the Supplier's request, afford all available assistance to the Supplier in conducting such proceedings or claim, and shall be reimbursed by the Supplier for all reasonable expenses incurred in so doing.

-
- 13.5 The Purchaser shall indemnify and hold harmless the Supplier and its employees, officers, and Subcontractors from and against any and all suits, actions or administrative proceedings, claims, demands, losses, damages, costs, and expenses of any nature, including attorney's fees and expenses, which the Supplier may suffer as a result of any infringement or alleged infringement of any patent, utility model, registered design, trademark, copyright, or other intellectual property right registered or otherwise existing at the date of the Contract arising out of or in connection with any design, data, drawing, specification, or other documents or materials provided or designed by or on behalf of the Purchaser.
14. Copyright 14.1 The copyright in all drawings, documents, and other materials containing data and information furnished to the Purchaser by the Supplier herein shall remain vested in the Supplier, or, if they are furnished to the Purchaser directly or through the Supplier by any third party, including suppliers of materials, the copyright in such materials shall remain vested in such third party.
15. Assignment 15.1 The Supplier shall not assign, in whole or in part, its obligations under the Contract, except with the Purchaser's prior written consent.
16. Sub contracting 16.1 The Supplier shall obtain approval of the Purchaser in writing of all Sub-Contracts to be awarded under the Contract if not already specified in the Tender. Sub-Contracting shall in no event relieve the Supplier from any of its obligations, duties, responsibilities, or liability under the Contract.
- 16.2 Subcontractors shall comply with the provisions of GCC Clause 3.
17. Supplier's Responsibilities 17.1 The Supplier shall supply all the Goods and Related Services specified in the Scope of Supply in conformity in all respects with the provisions of the Contract Agreement.
18. Purchaser's Responsibilities 18.1 The Purchaser shall pay the Supplier, in consideration of the provision of Goods and Related Services, the Contract Price or such other sum as may become payable under the provisions of the Contract at the times and manner prescribed in the Contract Agreement.
19. Scope of Supply 19.1 The Goods and Related Services to be supplied shall be as specified in Section 6: Schedule of Requirements.
- 19.2 Unless otherwise stipulated in the Contract, the Supply shall include all such items not specifically mentioned in the Contract but that can be reasonably inferred from the Contract as being required for attaining delivery of the Goods and completion schedule of the Related Services as if such items were expressly mentioned in the Contract.
20. Change Orders and Contract Amendments 20.1 The Purchaser may at any time order the Supplier through a notice in accordance with GCC Clause 12, to make changes within the general scope of the Contract in any one or more of the following:
- (a) drawings, designs, or specifications, where Goods to be furnished under the Contract are to be specifically manufactured for the Purchaser provided such changes do not

-
- materially affect the scope of supply;
- (b) the method of shipment or packing;
 - (c) the place of delivery; and
 - (d) the Related Services to be provided by the Supplier.
- 20.2 If any such change causes an increase or decrease in the cost of, or the time required for, the Supplier's performance of any provisions under the Contract, an equitable adjustment shall be made in the Contract Price or in the Delivery/Completion Schedule, or both, and the Contract shall accordingly be amended. Any claims by the Supplier for adjustment under this Clause must be submitted within twenty-eight (28) days from the date of the Supplier's receipt of the Purchaser's Change Order.
- 20.3 Prices to be charged by the Supplier for any Related Services that might be needed, but which were not included in the Contract, shall be agreed upon in advance by the parties and shall not exceed the prevailing rates charged to other parties by the Supplier for similar services.
21. Packing and Documents
- 21.1 The Supplier shall provide such packing of the goods as is required to prevent their damage or deterioration during transit to their final destination, as indicated in the Contract. During transit, the packing shall be sufficient to withstand, without limitation, rough handling and exposure to extreme temperatures, salt and precipitation, and open storage. Packing case size and weights shall take into consideration, where appropriate, the remoteness of the goods' final destination and the absence of heavy handling facilities at all points in transit.
- 21.2 The packing, marking, and documentation within and outside the packages shall comply strictly with such special requirements as shall be expressly provided for in the Contract, including additional requirements, if any, specified in the PCC, and in any subsequent instructions ordered by the Purchaser
22. Delivery and Documents and Acceptance
- 22.1 Subject to GCC Sub-Clause 20.1, the Delivery of the Goods and completion of the Related Services shall be in accordance with the Delivery and Completion Schedule specified in the Section 6: Schedule of Requirements.
- 22.2 The documents to be furnished by the Supplier shall be specified in the PCC, and shall be received by the Purchaser at least one week before arrival of the Goods and, if not received, the Supplier shall be responsible for consequent expenses.
- 22.3 Acceptance by the Purchaser shall be processed not later than fourteen (14) days from receipt of the goods at final destination in the form of an Acceptance Certificate, unless any defects in the supply, any damage during transport or any failure to meet the required performance criteria of the supply are identified and reported to the Supplier in accordance with GCC Clause 31 and GCC Clause 32. In such cases the Acceptance Certificate will be issued only for those

parts of the contract supplies which are accepted. The Acceptance Certificate for the remaining supplies will only be issued after the Supplier has remedied the defects and/or any non-conformity in accordance with GCC Clause 31 and GCC Clause 32.

23. Contract Price
- 23.1 The Contract Price shall be as specified in the Contract Agreement subject to any additions and adjustments thereto, or deductions therefrom, as may be made pursuant to the Contract.
- 23.2 Prices charged by the Supplier for the Goods delivered and the Related Services performed under the Contract shall not vary from the prices quoted by the Supplier in its Tender, with the exception of any price adjustments authorised in the PCC.
24. Transportation
- 24.1 Where the Supplier is required under the Contract to transport the Goods to a specified place of destination within Bangladesh, defined as the Site, transport to such place of destination including insurance, and other incidental costs, and temporary storage, if any, as shall be specified in the Contract, shall be arranged by the Supplier, and related costs shall be included in the Contract Price.
25. Spare Parts
- 25.1 As specified in the PCC, the Supplier may be required to provide any or all of the following materials, notifications, and information pertaining to spare parts manufactured or distributed by the Supplier:
- (a) such spare parts as the Purchaser may elect to purchase from the Supplier, provided that this election shall not relieve the Supplier of any warranty obligations under the Contract; and
 - (b) in the event of termination of production of the spare parts :
 - (i) advance notification to the Purchaser of the pending termination, in sufficient time to permit the Purchaser to procure needed requirements; and
 - (ii) following such termination, furnishing at no cost to the Purchaser, the blueprints, drawings, and specifications for the spare parts, if requested.
- 25.2 The Supplier shall carry sufficient inventories to assure ex-stock supply of spare parts as promptly as possible, but in any case within the time specified in the PCC for placing the order and opening the letter of credit.
26. Terms of Payment
- 26.1 The Contract Price, including any Advance Payments, if applicable, shall be paid in the manner as specified in the PCC.
- 26.2 The Supplier's request for payment shall be made to the Purchaser in writing, accompanied by an invoice describing, as appropriate, the Goods delivered and Related Services performed, and accompanied by the documents pursuant to GCC Clause 22 and upon fulfilment of any other obligations stipulated in the Contract.
- 26.3 Payments shall be made promptly by the Purchaser, no later than the dates indicated in the PCC.

-
- 26.4 In the event that the Purchaser fails to pay the Supplier any payment by its respective due date or within the period set forth in the PCC, the Purchaser shall pay to the Supplier interest on the amount of such delayed payment at the rate shown in the PCC, for the period of delay until payment has been made in full, whether before or after judgment or arbitration award.
27. Insurance 27.1 Unless otherwise specified in the PCC, the Goods supplied under the Contract shall be fully insured against loss or damage incidental to manufacture or acquisition, transportation, storage, and delivery, in the manner specified in the PCC.
28. Taxes and Duties 28.1 The Supplier shall be entirely responsible for all taxes, duties, license fees, and other such levies imposed or incurred until delivery of the contracted goods to the Purchaser.
29. Performance Security 29.1 In the case of Goods having warranty obligations the Performance Security shall be reduced to the amount specified in the PCC after delivery and acceptance of the Goods to cover the Supplier's warranty obligations in accordance with GCC Sub-Clause 32.3.
- 29.2 The Purchaser shall notify the Supplier of any claim made against the Bank issuing the Performance Security.
- 29.3. The Purchaser may claim against the security if any of the following events occurs for fourteen (14) days or more;
- (a) the Supplier is in breach of the Contract and the Purchaser has notified him that he is; and
 - (b) the Supplier has not paid an amount due to the Purchaser.
- 29.3 In the event the Supplier is liable to pay compensation under the Contract amounting to the full value of the Performance Security or more, the Purchaser may forfeit the full amount of the Performance Security.
- 29.4 If there is no reason to call the Performance Security, it shall be discharged by the Purchaser and returned to the Supplier not later than twenty-eight (28) days following the date of completion of the Supplier's performance obligations under the Contract, including any warranty obligations.
30. Specifications and Standards 30.1 The Supplier shall ensure that the Goods and Related Services comply with technical specifications and other provisions of the Contract.
- 30.2 The Supplier shall be entitled to disclaim responsibility for any design, data, drawing, specification or other document, or any modification thereof provided or designed by or on behalf of the Purchaser, by giving a notice of such disclaimer to the Purchaser.
- 30.3 The Goods and Related Services supplied under this Contract shall conform to the standards mentioned in Section 7: Technical Specifications and, when no applicable standard is mentioned, the

standard shall be equivalent or superior to the official standards whose application is appropriate to the goods' country of origin.

30.4 Wherever references are made in the Contract to codes and standards in accordance with which it shall be executed, the edition or the revised version of such codes and standards shall be those specified in the Schedule of Requirements. During Contract execution, any changes in any such codes and standards shall be applied only after approval by the Purchaser and shall be treated in accordance with GCC Clause 20.

31. Inspections and Tests

31.1 The Supplier shall at its own expense and at no cost to the Purchaser carry out all such tests and/or inspections of the Goods and Related Services as are specified in the Schedule of Requirements.

31.2 The inspections and tests may be conducted on the premises of the Supplier or its Subcontractor and/or at the Goods' final destination, or in another place in Bangladesh as specified in the PCC. Subject to GCC Sub-Clause 31.3, if conducted on the premises of the Supplier or its Subcontractor, all reasonable facilities and assistance, including access to drawings and production data, shall be furnished to the inspectors at no charge to the Purchaser.

31.3 The Purchaser or its designated representative shall be entitled to attend the tests and/or inspections referred to in GCC Sub-Clause 31.2, provided that the Purchaser bear all of its own costs and expenses incurred in connection with such attendance including, but not limited to, all travelling and board and lodging expenses.

31.4 Whenever the Supplier is ready to carry out any such test and inspection, it shall give a reasonable advance notice, including the place and time, to the Purchaser. The Supplier shall obtain from any relevant third party or manufacturer any necessary permission or consent to enable the Purchaser or its designated representative to attend the test and/or inspection.

31.5 The Purchaser may require the Supplier to carry out any test and/or inspection not required by the Contract, but deemed necessary to verify that the characteristics and performance of the Goods comply with the technical specifications, codes and standards under the Contract, provided that the Supplier's reasonable costs and expenses incurred in the carrying out of such test and/or inspection shall be added to the Contract Price. Further, if such test and/or inspection impede the progress of manufacturing and/or the Supplier's performance of its other obligations under the Contract, due allowance will be made in respect of the Delivery Dates and Completion Dates and the other obligations so affected.

31.6 The Supplier shall provide the Purchaser with a report of the results of any such test and/or inspection.

31.7 The Purchaser may reject any Goods or any part thereof that fail to pass any test and/or inspection or do not conform to the specifications. The Supplier shall either rectify or replace such rejected Goods or parts thereof or make alterations necessary to meet the specifications at no

cost to the Purchaser, and shall repeat the test and/or inspection, at no cost to the Purchaser, upon giving a notice pursuant to GCC Sub-Clause 31.4.

31.8 The Supplier agrees that neither the execution of a test and/or inspection of the Goods or any part thereof, nor the attendance by the Purchaser or its representative, nor the issue of any report pursuant to GCC Sub-Clause 31.6, shall release the Supplier from any warranties or other obligations under the Contract.

32. Warranty

32.1 The Supplier warrants that all the Goods are new, unused, and of the most recent or current models, and that they incorporate all recent improvements in design and materials, unless provided otherwise in the Contract.

32.2 Subject to GCC Sub-Clause 30.1, the Supplier further warrants that the Goods shall be free from defects arising from any act or omission of the Supplier or arising from design, materials, and workmanship, under normal use in the conditions prevailing in Bangladesh.

32.3 Unless otherwise specified in the PCC, the warranty shall remain valid for twelve (12) months after the Goods, or any portion thereof as the case may be, have been delivered to and accepted at the final destination indicated in the PCC.

32.4 The Purchaser shall give notice to the Supplier stating the nature of any such defects together with all available evidence thereof, promptly following the discovery thereof. The Purchaser shall afford all reasonable opportunity for the Supplier to inspect such defects.

32.5 Upon receipt of such notice, the Supplier shall, within the period specified in the PCC, expeditiously repair or replace the defective Goods or parts thereof, at no cost to the Purchaser.

32.6 If having been notified, the Supplier fails to remedy the defect within the period specified in the PCC; the Purchaser may proceed to take within a reasonable period such remedial action as may be necessary, at the Supplier's risk and expense and without prejudice to any other rights which the Purchaser may have against the Supplier under the Contract.

33. Extensions of Time

33.1 If at any time during performance of the Contract, the Supplier or its subcontractors should encounter conditions impeding timely delivery of the Goods or completion of Related Services pursuant to GCC Clause 22, the Supplier shall promptly notify the Purchaser in writing of the delay, its likely duration, and its cause. As soon as practicable after receipt of the Supplier's notice, the Purchaser shall evaluate the situation and may at its discretion extend the Supplier's time for performance, in which case the extension shall be ratified by the Parties by amendment of the Contract.

33.2 Except in the case of Force Majeure, as provided under GCC Clause 37, a delay by the Supplier in the performance of its Delivery and Completion obligations shall render the Supplier liable to the imposition of liquidated damages pursuant to GCC Clause 34, unless an extension of time is agreed upon, pursuant to GCC Sub-Clause 33.1.

-
34. Liquidated Damages 34.1 Except as provided under GCC Clause 37, if the Supplier fails to deliver any or all of the Goods or perform the Related Services within the period specified in the Contract, the Purchaser may, without prejudice to all its other remedies under the Contract, deduct from the Contract Price, as liquidated damages, a sum equivalent to the percentage specified in the PCC of the Contract Price of the delayed Goods and/or Related Services for each week or part thereof of delay until actual delivery or performance, up to a maximum deduction of the percentage specified in those PCC. Once the maximum is reached, the Purchaser may terminate the Contract pursuant to GCC Clause 38.
35. Limitation of Liability 35.1 Except in cases of criminal negligence or wilful misconduct ,
- (a) the Supplier shall not be liable to the Purchaser, whether in contract, tort, or otherwise, for any indirect or consequential loss or damage, loss of use, loss of production, or loss of profits or interest costs, provided that this exclusion shall not apply to any obligation of the Supplier to pay liquidated damages to the Purchaser and
 - (b) the aggregate liability of the Supplier to the Purchaser, whether under the Contract, in tort or otherwise, shall not exceed the total Contract Price, provided that this limitation shall not apply to the cost of repairing or replacing defective equipment, or to any obligation of the supplier to indemnify the Purchaser with respect to patent infringement.
36. Change in Laws and Regulations 36.1 Unless otherwise specified in the Contract, if after the date twenty eight (28) days before the submission of Tenders for the Contract, any law, regulation, ordinance, order or bylaw having the force of law is enacted, promulgated, abrogated, or changed in Bangladesh (which shall be deemed to include any change in interpretation or application by the competent authorities) that subsequently affects the Delivery Date and/or the Contract Price, then such Delivery Date and/or Contract Price shall be correspondingly increased or decreased, to the extent that the Supplier has thereby been affected in the performance of any of its obligations under the Contract. Notwithstanding the foregoing, such additional or reduced cost shall not be separately paid or credited if the same has already been accounted for in the price adjustment provisions where applicable, in accordance with GCC Clause 23.
37. Force Majeure 37.1 The Supplier shall not be liable for forfeiture of its Performance Security, liquidated damages, or termination for default if and to the extent that its delay in performance or other failure to perform its obligations under the Contract is the result of an event of Force Majeure.
- 37.2 For purposes of this Clause, “Force Majeure” means an event or situation beyond the control of the Supplier that is not foreseeable, is unavoidable, and its origin is not due to negligence or lack of care on the part of the Supplier. Such events may include, but not be limited to, acts of the Purchaser in its sovereign capacity, wars or revolutions, fires, floods, epidemics, quarantine restrictions, and freight embargoes.

37.3 If a Force Majeure situation arises, the Supplier shall promptly notify the Purchaser in writing of such condition and the cause thereof. Unless otherwise directed by the Purchaser in writing, the Supplier shall continue to perform its obligations under the Contract as far as is reasonably practical, and shall seek all reasonable alternative means for performance not prevented by the Force Majeure event.

38. Termination

38.1 Termination for Default

- (a) The Purchaser, without prejudice to any other remedy for breach of Contract, by giving twenty eight (28) days written notice of default, may terminate the Contract in whole or in part:
 - (i) if the Supplier fails to deliver any or all of the Goods within the period specified in the Contract, or within any extension thereof granted by the Purchaser pursuant to GCC Clause 33; or
 - (ii) if the Supplier fails to perform any other obligation under the Contract.
- (b) In the event the Purchaser terminates the Contract in whole or in part, pursuant to GCC Sub-Clause 38.1(a), the Purchaser may procure, upon such terms and in such manner as it deems appropriate, Goods or Related Services similar to those undelivered or not performed, and the Supplier shall be liable to the Purchaser for any additional costs for such similar Goods or Related Services. However, the Supplier shall continue performance of the Contract to the extent not terminated.
- (c) If the Supplier, in the judgment of the Purchaser has engaged in corrupt, fraudulent, collusive or coercive practices, as defined in GCC Clause 3, in competing for or in executing the Contract.

38.2 Termination for Insolvency.

- (a) The Purchaser and the Supplier's may at any time terminate the Contract by giving notice to the other party if either of the party becomes bankrupt or otherwise insolvent. In such event, termination will be without compensation to any party, provided that such termination will not prejudice or affect any right of action or remedy that has accrued or will accrue thereafter to the other party.

38.3 Termination for Convenience.

- (a) The Purchaser, by notice sent to the Supplier, may terminate the Contract, in whole or in part, at any time for its convenience. The notice of termination shall specify that termination is for the Purchaser's convenience, the extent to which performance of the Supplier under the Contract is terminated, and the date upon which such termination

becomes effective.

- (b) The Goods that are complete and ready for shipment within twenty-eight (28) days after the Supplier's receipt of notice of termination shall be accepted by the Purchaser at the Contract terms and prices. For the remaining Goods, the Purchaser may elect:
 - (i) to have any portion completed and delivered at the Contract terms and prices; and/or
 - (ii) to cancel the remainder and pay to the Supplier an agreed amount for partially completed Goods and Related Services and for materials and parts previously procured by the Supplier.

39. Settlement of Disputes 39.1 Amicable Settlement

- (a) The Purchaser and the Supplier shall use their best efforts to settle amicably all disputes arising out of or in connection with this Contract or its interpretation.

39.2 Arbitration

- (a) If the Parties are unable to reach a settlement as per GCC Clause 39.1(a) within twenty-eight (28) days of the first written correspondence on the matter of disagreement, then either Party may give notice to the other party of its intention to commence arbitration in accordance with GCC Sub-Clause 39.2(b).
- (b) The arbitration shall be conducted in accordance with the Arbitration Act (Act No 1 of 2001) of Bangladesh as at present in force and in the place shown in the PCC.

Section 4. Particular Conditions of Contract

<i>Instructions for completing the Particular Conditions of Contract are provided, as needed, in the notes in italics mentioned for the relevant GCC clauses.</i>	
GCC Clause	Amendments of, and Supplements to, Clauses in the General Conditions of Contract
GCC 1.1 (h)	The nature of the goods to be supplied is Supply, Installation, Testing and Commissioning of Video conferencing system for District, Divisional and Central Administrations
GCC 1.1(j)	The Purchaser is, Director (Procurement) Bangladesh Telecommunications Company Limited Sher-E-Banglanagar Telephone Annex Building (2 nd floor) Sher-E-Banglanagar, Dhaka. Telephone:8150500, Facsimile number: 8150511 Electronic mail address: ddclpct@btcl.net.bd
GCC 1.1(n)	The Supplier is <i>[Name, address, and name of authorized representative]</i> .
GCC 5.1(j)	The following documents shall also be part of the Contract: None
GCC 6.1	Suppliers and Sub-contractors from the following countries are not eligible: Israel
GCC 6.2	Goods and Related Services from the following countries are not eligible: Israel
GCC 7.1	Routine correspondence between the parties will be in Bangla/English.
GCC 12.1	For notices , the Purchaser's contact details shall be: Attention: Director Director (Procurement) Bangladesh Telecommunications Company Limited Sher-E-Banglanagar Telephone Annex Building (2 nd floor) Sher-E-Banglanagar, Dhaka. Telephone:8150500, Facsimile number: 8150511 Electronic mail address: ddclpct@btcl.net.bd

	<p>For notices, the Supplier's contact details shall be:</p> <p>Attention:</p> <p>Address:</p> <p>Telephone:</p> <p>Facsimile number:</p> <p>Electronic mail address:</p>
<p>GCC 21.2</p>	<p>A complete packing list indicating the content of each package shall be enclosed in a water proof envelope and shall be secured to the outside of the packing case. In addition, each package shall be marked with indelible ink/paint in bold letters, as follows:</p> <ol style="list-style-type: none"> a. Contract Number b. Name and address of Purchaser c. Country of origin d. Gross weight e. Net weight f. Package number of total number of packages g. Brief description of the content <p>Upright markings, where appropriate, shall be placed on all four vertical sides of the package.</p> <p>All materials used for packing shall be environmentally neutral.</p> <p>Additional marking and documentation within and outside the packages shall be: None</p>
<p>GCC 22.2</p>	<p>The documents to be provided are as follows:</p> <ol style="list-style-type: none"> (a) copies of Supplier's invoice showing goods' description, quantity, unit price, total amount; (b) copies of the packing list identifying the contents of each package; (c) manufacturer's/ supplier's warranty certificate (if any); (d) inspection certificate issued by the nominated inspection agency (or Purchaser) and/ or the supplier's factory inspection report (if any); (e) certificate of origin. (f) Document to prove that the video conferencing equipments, Routers, Switches and UPSs have been purchased from the authorized distributor/agent of the manufacturer.
<p>GCC 23.2</p>	<p>The prices charged for the Goods delivered and the Related Services to be performed shall be fixed for the duration of the contract.</p>

GCC 25.1	Additional spare parts requirements are specified in Annex- [] of the Specifications. None
GCC 25.2	Within [] weeks of placing the order and opening the letter of credit. Not Applicable.
GCC 26.1	The method and conditions of payment to be made to the Supplier under this Contract shall be as follows: 1. The payments shall be made through cheque (a) Directly from the designated accounts office of the Purchaser.
	2. Payments shall be made in Bangladesh Taka in the following manner : (a) 50% of the total price of the Equipment/Goods will be paid to the contractor upon receipt of the delivered Equipment/Goods in good condition at BTCL premises. In this regard the concerned officer of BTCL will issue a certificate of receipt of Equipment/Goods in good condition. (b) 45% of the total price of the Equipment/Goods will be paid to the contractor within twenty eight (28) days of submission of a claim supported by the Provisional Acceptance Certificate (PAC) issued by the Purchaser. The Director (M&O), BTCL will arrange to constitute an Acceptance Test Team and will issue the Provisional Acceptance Certificate upon recommendation of Team after successful completion of the Test. (c) Rest 5% of the total price of the Equipment/Goods will be paid to the contractor within twenty eight (28) days of submission of a claim supported by the Final Acceptance Certificate (FAC) issued by the Purchaser. The Director (M&O), BTCL will arrange to constitute an Acceptance Test Team and will issue the Final Acceptance Certificate upon recommendation of the Team after successful completion of the Test. (d) 95% of the total price of the Installation, Configuration and Commissioning Services will be paid to the contractor within twenty eight (28) days of submission of a claim supported by the Provisional Acceptance Certificate (PAC). (e) Rest 5% of the total price of the Installation, Configuration and Commissioning Services will be paid to the contractor within twenty eight (28) days of submission of a claim supported by the Final Acceptance Certificate (FAC). (f) 100% of the whole contract price for Training (Orientation, O&M Training, and overseas training) services shall be paid upon submission by the contractor of the "Certificate for Successful Completion of Training" to support his claim. Such a certificate shall be issued by concerned/ authorized official of BTCL as per terms described in this document.

	<p>(g) 100% of the whole contract price for Survey, Planning & Network Design Services shall be paid upon submission by the Contractor of a “Certificate for Successful Completion of Design Services” to support his claim. Such a certificate shall be issued by concerned/ authorized official of BTCL as per terms described in this document.</p> <p>(h) 100% of the total price of the Maintenance support during Guarantee period will be paid to the contractor upon successful completion of guarantee period. In this regard the Director (M&O) of BTCL will issue a Certificate of successful completion of Maintenance support during the guarantee period.</p> <p>(i) The total price of the Post Guarantee Maintenance Support services for each year will be paid to the contractor on half yearly basis upon successful completion of the services for the concerned period. In this regard, the Director (M&O) of BTCL will issue a Certificate of successful completion of Maintenance Support services for the concerned period.</p> <p>(j) 100% of the total price for “Provisional Acceptance Test” services will be paid to the contractor within twenty eight (28) days of submission of a claim supported by the Provisional Acceptance Certificate (PAC).</p> <p>(k) 100% of the total price for “Final Acceptance Test” Services will be paid to the contractor within twenty eight (28) days of submission of a claim supported by the Final Acceptance Certificate (FAC).</p>
GCC 26.4	The payment-delay period after which the Purchaser shall pay interest to the supplier shall be [] days. Not applicable.
GCC 27.1	“All risks” insurance, including “war risks, riots, and/or strikes” shall be acquired for 110% of the delivered cost of the goods on “Warehouse to Warehouse” basis.
GCC 29.1	The Performance Security shall be reduced to [%] percent of the Contract Price. Not Applicable
GCC 31.2	<p>The purchaser will not send any representative to the supplier’s / manufacturer’s premises for test / inspection of the equipment. The Inspections and tests shall be conducted at the relevant sites.</p> <p>The Purchaser’s right to inspect, test and where appropriate reject the Goods after delivery, shall in no way be limited or waived by the reason of Goods having previously been inspected, tested or passed by any authority prior to the Goods shipment.</p> <p>The bidder shall include price for such inspect/test (if any) in the price offered.</p>

GCC 32.3	<p>The period of validity of the Guarantee/Warranty shall be: One year starting from the date of issuance of the last PAC.</p> <p>For purposes of the Warranty, the place of final destination shall be: Director (M&O) or its successor, BTCL</p>
GCC 32.5	<p>The period for repair or replacement shall be: As quickly as possible but shall not more than 30 (thirty) calendar days.</p>
GCC 34.1	<p>The liquidated damage shall be one half of one percent (0.5%) of the Contract value per week or part thereof.</p> <p>The maximum amount of liquidated damages shall be: Ten (10%) of the Contract value.</p>
GCC 39.3(b)	<p>Arbitration shall take place in: BTCL H/Q. Any dispute and complaint shall be resolved under Public Procurement Regulations-2008.</p>

Section 5. Tender and Contract Forms

Form	Title
Tender Forms	
G – 1	Tender Submission Sheet
G – 2	Price Schedule
G – 3	Specifications Submission Sheet
G – 4	Tenderer Information Sheet
G – 5	Manufacturer's Authorisation Letter
G – 6	Bank Guarantee for Tender Security

Contract Forms	
G – 7	Notification of Award
G – 8	Contract Agreement
G – 9	Bank Guarantee for Performance Security
G – 10	Bank Guarantee for Advance Payment

Forms G1 to G6 comprise part of the Tender and should be completed as stated in ITT Clause 17.

Forms G7 to G10 comprise part of the Contract as stated in GCC Clause 5.

Tender Submission Sheet (Form G – 1)

Invitation for Tender No:

Date:

Tender Package No:

To:

[Name and address of Purchase]

We, the undersigned, offer to supply in conformity with the Tender Document the following Goods and Related Services, viz:

The total price of our Tender, excluding price reduction(s) is:

Tk:

insert value in figures (insert value in words)

If applicable under Instruction to Tenderers (ITT) Sub-Clause 20.3, and in case we are awarded a contract for more than one lot in the package, the discounts / cross- discounts offered, and the methodology for its application is:

We undertake, if our Tender is accepted, to deliver the goods in [] (weeks / months) from the date of [], in accordance with the delivery schedule specified in the Schedule of Requirements.

We are not participating as Tenderers in more than one Tender in this Tendering process. Our Tender shall be valid for the period stated in the Tender Data Sheet and it shall remain binding upon us and may be accepted at any time before the expiration of that period. A Tender Security in the amount stated in the Tender Data Sheet is attached in the form of a *[state pay order, bank draft, bank guarantee]* valid for a period of 28 days beyond the Tender validity date.

If our Tender is accepted, we commit to obtaining a Performance Security in the amount stated in the Tender Data Sheet and valid for a period of 28 days beyond the date of completion of our performance obligations under the Contract, including any warranty obligations.

We declare that ourselves, and any subcontractors or suppliers for any part of the Contract, have nationalities from eligible countries and that the goods and related services will also be supplied from eligible countries. We also declare that the Government of Bangladesh has not declared us, and any subcontractors or suppliers for any part of the Contract, ineligible on charges of engaging in corrupt, fraudulent, collusive or coercive practices. We furthermore, pledge not to indulge in such practices in competing for or in executing the Contract, and are aware of the relevant provisions of the Tender Document (ITT Clause 3).

We understand that your written Notification of Award shall constitute the acceptance of our Tender and shall become a binding contract between us, until a formal contract is prepared and executed.

We understand that you are not bound to accept the lowest evaluated Tender or any other Tender that you may receive.

Signed

In the capacity of:

Duly authorised to sign the Tender on behalf of the Tenderer.

Date:

Price Schedule for Goods (Form G-2A)

Invitation for Tender No:
Tender Package No:

Date:

A: PRICE OF GOODS AND DELIVERY SCHEDULE

1	2	3	4	5	6	7	8	9	10	11
Item No.	Description Of Item	Unit Of Supply	Qty Of units Required	Unit price EXW	Total price EXW (col. 4 × 5)	Extra Price to deliver Goods to final destination	Total price Delivered (col. 6 +7)	VAT and other taxes payable if contract is awarded	Total price including VAT and Tax (col. 8+9)	Point of Delivery And Delivery Period Offered
				Note 1 / Note 2		Note 3		Note 4	Note 5	
A.	VC Equipment for High End User (2 locations)									
1.	End Terminals with all accessories (with integrated wheel based floor stand)	system	2							
2.	50 inch. HD LCD Display Unit	set	4							
3.	Multimedia Projector	set	2							
4.	Projector Screen	set	2							
B.	VC Equipment for Standard User (73 locations*)									
5.	End Terminals with all accessories	system	73							
6.	46 inch HD LCD Display Unit	set	73							
7.	Wheel based floor stand/Trolley	set	73							
C.	MCU (Multi-point control unit (MCU)) Equipment									

1	2	3	4	5	6	7	8	9	10	11
Item No.	Description Of Item	Unit Of Supply	Qty Of units Required	Unit price EXW	Total price EXW (col. 4 × 5)	Extra Price to deliver Goods to final destination	Total price Delivered (col. 6 +7)	VAT and other taxes payable if contract is awarded	Total price including VAT and Tax (col. 8+9)	Point of Delivery And Delivery Period Offered
8.	30-point Multi-point control unit (MCU)	set	1							
9.	16-point Multi-point control unit (MCU)	set	2							
10.	12-point Multi-point control unit (MCU)	set	4							
D.	Equipments at Central Site (Dhaka)									
11.	Content Server	system	1							
12.	Recording Server	system	1							
13.	Scheduling Server	system	1							
14.	Management and Reporting System	system	1							
15.	Accessories e.g. KVM switch, Server Rack, 17" monitor, Keyboard, Mouse etc. (if any)	lot	1							
16.	Management Terminal									
a.	Desktop Terminal	set	2							
b.	Portable Terminal	set	2							
17.	Communication Server	system	1							
18.	Others, if any	system	1							
E.	Networking and Power Equipment at end-points									
19.	Central Router	set	1							
20.	Type-I LAN switch	set	1							
21.	Type-II LAN switch	set	75							
22.	Ethernet to E1 Converter	set	Bidder will quote							
23.	E1 to Ethernet Converter	set	30							

1	2	3	4	5	6	7	8	9	10	11
Item No.	Description Of Item	Unit Of Supply	Qty Of units Required	Unit price EXW	Total price EXW (col. 4 × 5)	Extra Price to deliver Goods to final destination	Total price Delivered (col. 6 +7)	VAT and other taxes payable if contract is awarded	Total price including VAT and Tax (col. 8+9)	Point of Delivery And Delivery Period Offered
24.	Media Converter	set	3							
25.	24-port wall ODF (FC type)	set	75							
26.	ETSI-standard Cabinet-	set	77							
27.	Double Conversion Online UPS, 5KVA, 1 hr backup at full load	set	2							
28.	Double Conversion Online UPS, 2KVA, 2 hr backup at full load, Type-1	set	66							
29.	Double Conversion Online UPS, 2KVA, 2 hr backup at full load, Type-2	set	7							
F.	Other Equipment/Items									
30.	License for PC/Laptop User	Nos.	75							
31.	Any other item (if required)									

* 73 (Seventy Three) locations include 64 x Deputy Commissioner's Office, 7 x Divisional Commissioner's Office and two locations to be decided later on.

Note 1: EXW means Ex-works; Ex-factory; Ex-warehouse; Ex-show-room, or off-the-shelf as applicable

Note 2: Unit Price EXW shall include all custom duties and taxes as specified in ITT Sub-Clause 20.5(a)

Note 3: Price for inland transportation shall include insurance and other costs as specified in ITT Sub-Clause 20.5(c)

Note 4: VAT and any other taxes payable in Bangladesh shall be included here as specified in ITT Sub-Clause 20.5(b)

Note 5: Tenderer shall mention the sum of total price of column 10 of this Form-G2A and the total price of column 10 of the Form-G2B in Form G-1 excluding the price reduction (if any).

Note 6: Any conditional price quotation shall cause the bid to be rejected as "Non-Responsive".

Name of Tenderer _____ Signature of Tenderer _____ Date _____

Price Schedule for Related Services (Form G-2B)

Invitation for Tender No:
Tender Package No:

Date

B: PRICE OF RELATED SERVICES AND COMPLETION SCHEDULE

1	2	3	4	5	6	7	8	9	10	11
Item N° .	Description Of Related Service	Unit of Supply	Qty Of units Required	Unit price	Total price (col. 4 × 5)	Other Related Costs	Total price (col. 6 +7)	VAT and other taxes payable if contract is awarded	Total price including VAT and Tax (col. 8+9)	Point of Delivery And date Required
		Note 1	Note 1			Note 1		Note 2	Note 3	
1.	Installation, Configuration & Commissioning of Video Conference system	lot	1							As per section-7
2.	Orientation for District, Divisional and Central Administration Personnel	lot	1							
3.	O & M Training for BTCL Officials (In Dhaka)	lot	1							
4.	Overseas Training & System Visit	lot	1							
5.	Survey, Network Planning & Design Services	lot	1							
6.	Provisional Acceptance Test	lot	1							
7.	Final Acceptance Test	lot	1							
8.	Maintenance support during warranty period	lot	1							
9.	Post Guarantee Maintenance support for two years	lot	1							

Note 1: The Tenderer will complete these columns as appropriate following the details specified in Section 6: Schedule of Requirements
 Note 2: VAT and any other taxes payable in Bangladesh shall be included here as specified in ITT Sub-Clause 20.5(b)
 Note 3: Tenderer shall mention the sum of total price of column 10 of this Form-G2B and the total price of column 10 of the Form-G2A in Form G-1 excluding the price reduction (if any).

Note 4: Any conditional price quotation shall cause the bid to be rejected as “Non-Responsive”.

Price Schedule for Optional Item (Form-G2C)

1	2	3	4	5	6	7	8	9	10	11
Item N° .	Description Of Related Service	Unit of Supply	Qty Of units Required	Unit price	Total price (col. 4 × 5)	Other Related Costs	Total price (col. 6 +7)	VAT and other taxes payable if contract is awarded	Total price including VAT and Tax (col. 8+9)	Point of Delivery And date Required
		Note 1	Note 1			Note 1		Note 2	Note 3	
1.	Annual Operation Cost of the System	lot	1							As per section-7

Name of Tenderer _____ Signature of Tenderer _____ Date _____

Specifications Submission Sheet (Form G-3)

Invitation for Tender No:
Tender Package No:

Date

Item No	Name of Goods or Related Service	Country of Origin	Make and Model <i>(when applicable)</i>	Full Technical Specifications and Standards
1	2	3	4	5
	FOR GOODS			
	Lot No. 1			
	<i>[The bidder shall add here the list of items mentioned in "Section 6: Schedule of Requirements" and will add as many rows and details as there are individual items]</i>			<i>[the Tenderer should complete columns 3, 4 and 5 as required]</i>
	FOR RELATED SERVICES			
	Lot No. 1			
	<i>[The bidder shall add here the list of items mentioned in "Section 6: Schedule of Requirements" and will add as many rows and details as there are individual items]</i>			<i>[the Tenderer should complete columns 3, 4 and 5 as required]</i>

Name of Tenderer _____ Signature of Tenderer _____ Date _____

Tenderer Information Sheet (Form G-4)

Date

Invitation for Tender No:

Tender Package No:

A. Individual Tenderers

1. General Information of the Tenderer	
1.1	Tenderer's Legal Name
1.2	Tenderer's legal address in Country of Registration
1.3	Tenderer's legal status
	Proprietorship
	Partnership (Registered under the Partnership Act, 1932)
	Limited Liability Concern (Registered under the Companies Act, 1913)
	Others
1.4	Tenderer's Year of Registration
1.5	Tenderer's business status
	Manufacturer
	Local Agent/Distributor of a foreign Manufacturer
	Stockist
	Others
1.6	Tenderer's Authorised Representative Information
	Name
	Address
	Telephone / Fax Numbers
	e-mail address
1.7	Tenderer's Value Added Tax Registration Number
1.8	Tenderer's Income Tax Identification Number (TIN)

1.9	Tenderer to attach copies of the following documentation:	<p>(a) Articles of Incorporation or Registration of firm.</p> <p>(b) Latest Income Tax Clearance Certificate</p> <p>(c) Latest VAT Registration Certificate</p> <p>(d) Original letter naming the person authorised to sign on behalf of the Tenderer</p> <p>(e) Others <i>(to be completed by the Purchaser if required)</i></p>
2. Qualification Information of the Tenderer		
2.1	Number of years of overall experience of the Tenderer in the supply of goods and related services:	[write "Not applicable", if this information is not asked in ITT 12.1(a)]
2.2	Number of years of specific experience of the Tenderer in the supply of similar goods and related services:	[write "Not applicable", if this information is not asked in ITT 12.1(b)]
2.3	Total annual monetary value of similar goods supplied in each of the last five years.	[write "Not applicable", if this information is not asked in ITT 13.1(a)]
2.4	Available liquid assets	[write "Not applicable", if this information is not asked in ITT 13.1(b)]
2.5	Details of production capacity/ equipment available:	[write "Not applicable", if this information is not asked in ITT 12.1(c)]
2.6	Major supplies of similar type of Goods over the last five years. Also list details of supplies of similar type of Goods under way or committed, including expected delivery date.	
3. Financial Information of the Tenderer		
3.1	Financial reports or balance sheets or profit and loss statements or auditors' reports or bank references with documents or a combination of these demonstrating availability of liquid assets. List below and attach copies.	
3.2	Name, address, and telephone, telex, and facsimile numbers of banks that may provide references if contacted by the Employer	
3.3	Information on litigation in which the Tenderer is, or has been, involved:	
	(a) Any case within the past five years	
	Cause of Dispute	Result of Settlement and amount

	(b) Current cases in this financial year	
	Cause of Dispute	Current Position of Case
<p><i>Note: The above represents the minimum requirements. These may be added to buy the Purchaser on a case-by-case basis, as necessary.</i></p>		

B. Individual Members of a Joint Venture

4.1	Each Member of a JVCA shall provide all the information requested in the form above, Sections 1-3.
4.2	Attach a power of attorney for each of the authorising signatories of the Tender on behalf of the JVCA.
4.3	<p>Attach the Agreement among all Members of the JVCA (and which is legally binding on all Members), which shows that:</p> <ul style="list-style-type: none"> (a) all Members shall be jointly and severally liable for the execution of the Contract in accordance with the Contract terms; (b) one of the Members will be nominated as being in charge, authorised to incur liabilities, and receive instructions for and on behalf of any and all Members of the joint venture; and (c) the execution of the entire Contract, including payment, shall be done exclusively with the Member in charge
<p><i>Note: The above represents the minimum requirements. These may be added to buy the Purchaser on a case-by-case basis, as necessary.</i></p>	

Manufacturer's Authorisation Letter (Form G - 5)

[This letter of authorisation should be on the letterhead of the manufacturer and should be signed by the person with the proper authority to sign documents that are binding on the manufacturer]

Invitation for Tender No:

Date:

Tender Package No:

To:

Name and address of Purchaser]

WHEREAS, we *[name and address of manufacturer]* are reputable manufacturers having factories at *[list of places of factories]*.

THEREFORE, we do hereby:

1. Authorise *[name of Tenderer]* to submit a Tender in response to the Invitation for Tenders indicated above, the purpose of which is to provide the following Goods, *[description of goods]*, manufactured by us, and to subsequently sign the Contract for the supply of such Goods; and,
2. Extend our full guarantee and warranty in accordance with GCC Clause 32, with respect to the Goods offered in the Tender.

Signed

In the capacity of:

Duly authorised to sign the authorisation for and on behalf of

[name of manufacturer]

Date:

Bank Guarantee for Tender Security (Form G – 6)

[this is the format for the Tender Security to be issued by a scheduled bank of Bangladesh in accordance with ITT Clause 27]

Invitation for Tender No:

Date:

Tender Package No:

To:

[Name and address of Purchaser]

TENDER GUARANTEE No:

We have been informed that *[name of Tenderer]* (hereinafter called “the Tenderer”) intends to submit to you its Tender dated *[date of Tender]* (hereinafter called “the Tender”) for the supply of *[description of goods and related services]* under the above Invitation for Tenders (hereinafter called “the IFT”).

Furthermore, we understand that, according to your conditions Tenders must be supported by a Tender guarantee.

At the request of the Tenderer, we *[name of bank]* hereby irrevocably undertake to pay you, without cavil or argument, any sum or sums not exceeding in total an amount of Tk *[insert amount in figures and in words]* upon receipt by us of your first written demand accompanied by a written statement that the Tenderer is in breach of its obligation(s) under the Tender conditions, because the Tenderer:

- (a) has withdrawn its Tender during the period of Tender validity specified by the Tenderer in the Form of Tender; or
- (b) does not accept the correction of errors in accordance with the Instructions to Tenderers of the IFT; or
- (c) having been notified of the acceptance of the Tender by the Purchaser during the period of Tender validity, (i) fails or refuses to furnish the Performance Security in accordance with the ITT, or (ii) fails or refuses to execute the Contract Form,

This guarantee will expire :

- (a) if the Tenderer is the successful Tenderer, upon our receipt of a copy of the Performance Security and a copy of the Contract signed by the Tenderer as issued by you; or
- (b) if the Tenderer is not the successful Tenderer, twenty eight days after the expiration of the Tenderer’s Tender validity period, being *[date of expiration of the Tender]*.

Consequently, we must receive at the above-mentioned office any demand for payment under this guarantee on or before that date.

Signature

Signature

Notification of Award (Form G - 7)

Contract No:
To:

Date:

This is to notify you that your Tender dated *[insert date]* for the supply of goods and related services for *[name of project/contract]* for the Contract Price of Taka *[amount in figures and in words]*, as corrected and modified in accordance with the Instructions to Tenderers is hereby accepted by *[name of Procuring Entity]*.

You are requested to proceed with the supply of the goods and the related services and note that this Notification of Award shall constitute the formation of a Contract, which shall only become binding upon you furnishing a Performance Security within 14 days, in accordance with ITT Clause 50, and the signing of the Contract Agreement within 21 days, in accordance with ITT Clause 51.

We attach the Contract Agreement and Contract Documents for you perusal and signature.

Signed

Duly authorised to sign for and on behalf of
[name of Procuring Entity]

Date:

Contract Agreement (Form G - 8)

THIS AGREEMENT made the *[day]* day of *[month]* *[year]* between *[name and address of Purchaser]* (hereinafter called "the Purchaser") of the one part and *[name and address of Supplier]* (hereinafter called "the Supplier") of the other part:

WHEREAS the Purchaser invited Tenders for certain goods and related services, viz, *[brief description of goods and related services]* and has accepted a Tender by the Supplier for the supply of those goods and related services in the sum of Taka *[Contract Price in figures and in words]* (hereinafter called "the Contract Price").

NOW THIS AGREEMENT WITNESSETH AS FOLLOWS:

1. In this Agreement words and expressions shall have the same meanings as are respectively assigned to them in the General Conditions of Contract hereafter referred to.
2. The documents forming the Contract shall be interpreted in the following order of priority:
 - (a) the signed Form of Contract Agreement;
 - (b) the letter of Notification of Award
 - (c) the completed Tender Submission Sheet as submitted by the Tenderer;
 - (d) the completed Price Schedules as submitted by the Tenderer;
 - (e) the Particular Conditions of Contract;
 - (f) the General Conditions of Contract;
 - (g) the Schedule of Requirements;
 - (h) the Technical Specifications;
 - (i) the Drawings, and;
 - (j) any other document listed in the PCC as forming part of the Contract.
3. In consideration of the payments to be made by the Purchaser to the Supplier as hereinafter mentioned, the Supplier hereby covenants with the Purchaser to provide the goods and related services and to remedy any defects therein in conformity in all respects with the provisions of the Contract.
4. The Purchaser hereby covenants to pay the Supplier in consideration of the provision of the goods and related services and the remedying of defects therein, the Contract Price or such other sum as may become payable under the provisions of the Contract at the times and in the manner prescribed by the Contract.

IN WITNESS whereof the parties hereto have caused this Agreement to be executed in accordance with the laws of Bangladesh on the day, month and year first written above.

For the Purchaser:

For the Supplier:

Signature

Print Name

Title

In the presence
of
Name

Address

Bank Guarantee for Performance Security (Form G – 9)

[this is the format for the Performance Security to be issued by a scheduled bank of Bangladesh in accordance with ITT Clause 50]

Contract No:

Date:

To:

[Name and address of Purchaser]

PERFORMANCE GUARANTEE No:

We have been informed that *[name of supplier]* (hereinafter called “the Supplier”) has undertaken, pursuant to Contract No *[reference number of Contract]* dated *[date of Contract]* (hereinafter called “the Contract”) for the supply of *[description of goods and related services]* under the Contract.

Furthermore, we understand that, according to your conditions, Contracts must be supported by a performance guarantee.

At the request of the Supplier, we *[name of bank]* hereby irrevocably undertake to pay you, without cavil or argument, any sum or sums not exceeding in total an amount of Tk *[insert amount in figures and in words]* upon receipt by us of your first written demand accompanied by a written statement that the Supplier is in breach of its obligation(s) under the Contract conditions, without you needing to prove or show grounds or reasons for your demand of the sum specified therein.

This guarantee is valid until *[date of validity of guarantee]*, consequently, we must receive at the above-mentioned office any demand for payment under this guarantee on or before that date.

Signature

Signature

(NOT APPLICABLE)

Bank Guarantee for Advance Payment (Form G – 10)

[this is the format for the Advance Payment Security to be issued by a scheduled bank of Bangladesh in accordance with GCC Clause 26.1]

Contract No:

Date:

To:

[Name and address of Purchaser]

ADVANCE PAYMENT GUARANTEE No:

We have been informed that *[name of supplier]* (hereinafter called “the Supplier”) has undertaken, pursuant to Contract No *[reference number of Contract]* dated *[date of Contract]* (hereinafter called “the Contract”) for the supply of *[description of goods and related services]* under the Contract.

Furthermore, we understand that, according to your Particular Conditions of Contract Clause 26.1, Advance Payment(s) on Contracts must be supported by a bank guarantee.

At the request of the Supplier, we *[name of bank]* hereby irrevocably undertake to pay you, without cavil or argument, any sum or sums not exceeding in total an amount of Tk *[insert amount in figures and in words]* upon receipt by us of your first written demand accompanied by a written statement that the Supplier is in breach of its obligation(s) under the Contract conditions, without you needing to prove or show grounds or reasons for your demand of the sum specified therein.

We further agree that no change, addition or other modification of the terms of the Contract to be performed, or of any of the Contract documents which may be made between the Purchaser and the Supplier, shall in any way release us from any liability under this guarantee, and we hereby waive notice of any such change, addition or modification.

This guarantee is valid until *[date of validity of guarantee]*, consequently, we must receive at the above-mentioned office any demand for payment under this guarantee on or before that date.

Signature

Signature

Section 6. Schedule of Requirements

Invitation for Tender No:
Tender Package No:

Date

A. List of Goods and Delivery Schedule

When completing Form G-2 the Tenderer shall quote prices and contract delivery dates for each item against each lot and show each Lot separately, as specified in the List of Goods and Delivery Schedule.)

Item No.	Description of Item	Unit of Supply	Quantity of Units required	Point of Delivery	Date Required from date of contract signature (in weeks)
<i>1</i>	<i>2</i>	<i>3</i>	<i>4</i>	<i>5</i>	<i>6</i>
A.	VC Equipment for High End User (2 locations)				
1.	End Terminals with all accessories (with integrated wheel based floor stand)	system	2	BTCL site, Dhaka	12
2.	50 inch. HD LCD Display Unit	set	4	-do-	12
3.	Multimedia Projector	set	2	-do-	12
4.	Projector Screen	set	2	-do-	12
B.	VC Equipment for Standard User (73 locations*)				
5.	End Terminals with all accessories	system	73	In 64 district HQs	12
6.	46 inch HD LCD Display Unit	set	73	In 64 district HQs	12
7.	Wheel based floor stand/Trolley	set	73	In 64 district HQs	
C.	MCU (Multi-point control unit (MCU)) Equipment				
8.	30-point Multi-point control unit (MCU)	set	1	Dhaka	12
9.	16-point Multi-point control unit (MCU)	set	2	Chittagong, Khulna	12
10.	12-point Multi-point control unit (MCU)	set	4	Rajshahi, Rangpur, Barisal, Sylhet	12
D.	Equipments at Central Site (Dhaka)				
11.	Content Server	system	1	Dhaka	12
12.	Recording Server	system	1	Dhaka	12
13.	Scheduling Server	system	1	Dhaka	12
14.	Management and Reporting System	system	1	Dhaka	12
15.	Accessories e.g. KVM switch, Server Rack, 17" monitor, Keyboard, Mouse etc. (if any)	lot	1	Dhaka	12
16.	Management Terminal				

a.	Desktop Terminal	set	2	Dhaka	12
b.	Portable Terminal	set	2	Dhaka	12
17.	Communication Server	system	1	Dhaka	12
18.	Others, if any	system	1	Dhaka	12
E.	Networking and Power Equipment at end-points				
19.	Central Router	set	1	Dhaka	12
20.	Type-I LAN switch	set	1	Dhaka	12
21.	Type-II LAN switch	set	75	In 64 district HQs	12
22.	Ethernet to E1 Converter	set	Bidder will quote	In 14 district HQs	12
23.	E1 to Ethernet Converter	set	30	In 30 district HQs	12
24.	Media Converter	set	3	In 3 district HQs	12
25.	24-port ODF (FC type)	set	75	In 64 district HQs	12
26.	ETSI-standard Cabinet	set	77	In 64 district HQs	12
27.	Double Conversion Online UPS, 5KVA, 1 hr backup at full load	set	2	Dhaka	12
28.	Double Conversion Online UPS, 2KVA, 2 hr backup at full load, Type-1	set	66	In 64 district HQs	12
29.	Double Conversion Online UPS, 2KVA, 2 hr backup at full load, Type-2	set	7	In 7 divisional HQs	12
F.	Other Equipment/Items				
30.	License for PC/Laptop User	Nos.	75	Dhaka	12
31.	Any other item (if required)				12

* 73 (Seventy Three) locations include 64 x Deputy Commissioner's Office, 7 x Divisional Commissioner's Office and two locations to be decided later on.

B. List of Related Services and Completion Schedule

When completing Form G-2 the Tenderer shall quote prices and contract delivery dates for each item against each lot

Item No.	Description of Related Services	Unit of Supply	Quantity of Units Required	Point at which Services are required	Required Completion Date for Services from date of contract signature
<i>1</i>	<i>2</i>	<i>3</i>	<i>4</i>	<i>5</i>	<i>6</i>
1.	Installation, Configuration & Commissioning of Video Conference system	lot	1	All sites	20 weeks from signing of contract
2.	Orientation for District, Divisional and Central Administration Personnel	lot	1	Dhaka	28 weeks from signing of contract
3.	O & M Training for BTCL Officials (In Dhaka)	lot	1	Dhaka	24 weeks from signing of contract
4.	Overseas Training & System Visit	lot	1	Overseas Country(ies)	6 weeks from signing of contract
5.	Survey, Network Planning & Design Services	lot	1	All sites	4 weeks from signing of contract
6.	Provisional Acceptance Test	lot	1	All sites	20 weeks from signing of contract
7.	Final Acceptance Test	lot	1	All sites	Within 4 weeks from end of Guarantee Period
8.	Maintenance support during warranty period	lot	1	All sites	1 year from the date of PAC issue
9.	Post Guarantee Maintenance support for two years	lot	1	All sites	On completion of the concerned years

C. Optional Items

Item No.	Description of Item	Unit of Supply	Quantity of Units required	Point of Delivery
<i>1</i>	<i>2</i>	<i>3</i>	<i>4</i>	<i>5</i>
1.	Operation charge per year	Lot	1	All sites

Section 7 : Technical Specifications

Technical Specifications for Installation of Video Conferencing System for Districts, Divisional and Central Administrations

7.1 Scope of Works

7.1.1 Bangladesh Telecommunication Co. Ltd (BTCL) has been given responsibility to install a video conferencing network covering offices of all Deputy Commissioners, Divisional Commissioners, Cabinet Division and Prime Minister to increase efficiency of the administration through e-governance. For this purpose, a project has been undertaken by BTCL for the procurement of full video conference system, networking equipment, backup power system for all end- points, where end-point means Prime Minister's office, Cabinet Division, all Divisional Commissioners' offices and all Deputy Commissioners' offices where the video conferencing services will be provided.

To implement the video conference system, this tender proposes to procure the following equipment/items with installation services on turn-key basis:

- a) Two (2) Video Conference (VC) nodal equipment for high-end users to be installed at Cabinet Division, Bangladesh Secretariat and Prime Minister's Office.
- b) Seventy Three (73) Video Conference (VC) nodal equipment for standard users to be installed at the sixty four Deputy Commissioner, seven Divisional Commissioner's Office and two at the sites to be decided later on.
- c) Seven (7) Multipoint Control Unit (MCU) to be installed at the BTCL Exchange premises in Dhaka (Ramna), Chittagong (Central), Sylhet, Rangpur, Rajshahi, Khulna (Khalishpur), and Barisal.
- d) One central Router and one Type-I LAN Switch to be installed at Ramna BTCL exchange premise.
- e) Seventy Five (75) Type-II LAN Switches at the endpoints.
- f) Sixty Six (66) 2 KVA Type-1 double conversion online UPS, Seven (7) 2 KVA Type-2 Double Conversion Online UPS and Two (2) 5 KVA double conversion online UPS.
- g) Ethernet to E1 converter to be installed at BTCL exchange premises to split the uplink Ethernet bandwidth into multiple E1s to be carried towards multiple/single destination endpoints. The quantity of this converter will depend on the bidder based on the configuration of offered equipment.
- h) Thirty numbers of "E1 to Ethernet Converter" to be installed at BTCL exchange premises nearest to the endpoint for last mile connectivity.
- i) Three Media Converter (from electrical Ethernet to Optical Ethernet).
- j) One Communication Server with integrated Firewall and Gatekeeper functionality (or in separate devices) to be installed at BTCL Exchange premise in Dhaka (Ramna).
- k) Content, Recording, Streaming, Scheduling and Network Management Servers to be installed at BTCL Exchange premise in Dhaka (Ramna).
- l) Miscellaneous items like Racks, Optical Distribution Frame (ODF), Multimedia

Projector, White Screen etc.

7.1.2 Spares and consumables

The bidder shall supply, at his own cost, all necessary consumables to be used during installation, testing & commissioning of the network.

7.1.3 Spare Parts Guarantee

The Bidder shall provide a separate guarantee (*as per format in Annex- 1*) to the effect that, he shall guarantee the flow and availability of all spare parts and units without major design changes for at least 5 (five) years from “the date of effect” of the Provisional Acceptance Certificate (PAC). If, within this period, there is any major design change or stoppage of production of supplied equipment, the bidder shall bear all the costs related to provision of alternate solutions.

7.1.4 Maintenance Support

7.1.4.1 Maintenance Support up to Guarantee Period

The bidder shall quote for Maintenance Support during the Guarantee Period. The supports shall start from the date of cutover into operational service of the first equipment/ system purchased under this contract.³

The period of the service shall continue for 1 (*one*) *calendar year* from “**the date of effect**” of the last Provisional Acceptance Certificate (PAC) of the contract.

The format of the support is given in **Annex-2**.

7.1.4.2 Post Guarantee Maintenance Support after Guarantee Period

The Bidder shall quote for Post Guarantee Maintenance support for 2 (two) years starting after the end of the Guarantee Period to be provided as per format given in **Annex-3**.

7.1.5 Guarantee Period

The bidder’s offer shall include an overall “**Guarantee Period**” for all the equipment covered by this purchase. This period shall deem to have started from the cut-over of the first equipment into commercial service and last for 1 (one) calendar years from “**the date of effect**” of the last PAC of the contract.

7.1.6 Outsourcing service for System Operation

The Bidder shall quote the price of outsourcing service for system operation on annual basis. The services to be provided as per format given in **Annex-4**. The quotation is mandatory. The cost will not be added to the total cost during evaluation.

7.1.7 Testing

7.1.7.1 Provisional Acceptance Test (PAT)

Before acceptance of the installed system/ equipment, BTCL representatives shall carryout, on site, detailed tests of all equipment to ascertain their working reliability, concurrence to agreed technical and other specifications, inventory checking of installed equipment etc. Such tests shall

be termed as “**Provisional Acceptance Test (PAT)**”. Prior to commencement of such tests, the contractor shall submit a proposed procedure for the PAT to be subsequently passed by BTCL.

BTCL shall start such tests within one month after receipt the request. The bidder may, upon agreement by the both party, offer PAT for any part or parts of the total system. Such request for partial PAT may also be asked for by BTCL.

The bidder shall be totally responsible for arrangement of all equipment, consumables, test tools and measuring equipment etc. required for the PAT.

In addition, the bidder has to provide per-diem costs to PAT engineers as per following:

- | | |
|--|-------------------------|
| a) Number of members of PAT team | : 15 (Fifteen) |
| b) Max. number of man-day/endpoint (site) (excluding central site) | : 4 (Four) |
| c) Maximum number of man-day for central site | : 15 (Fifteen) |
| d) Per diem charge to PAT members | : Tk.1,000/-per man-day |

However, the bidder shall note that, if for any reason the PAT continues for more than the above scheduled period, the bidder shall not be liable to pay per-diem for those additional days. The bidder shall provide local transportation to the PAT Team to conduct the PAT.

7.1.7.2 Issuance of Provisional Acceptance Certificate (PAC)

- i) The PAT team shall check the compliance statement of the bidder and the contract. Compliance statement of the bidder & the contract conditions shall be implemented/fulfilled with full satisfaction to BTCL.
- ii) PAT team shall check the quality of the installation materials which must be standard & world class and with full compliance to technical specification.
- iii) The contractor will be given 14 days for completion of the works pointed out by PAT team.
- iv) The bidder shall take all necessary actions for cut over of the system on the date fixed up by BTCL irrespective of PAC, whether issued or not.
- v) Upon recommendation of the PAT team, the concerned authority of BTCL will issue the PAC.

7.1.7.3 Final Acceptance Test (FAT)

- i) After completion of the PAT and cut-over of the system, the Engineers of the Bidder will take prompt necessary steps to remove all types of faults and replace all types of faulty equipment at the cost of the supplier. At the end of the “Performance Guarantee Period for the Contract”, the overall performance of all equipment will be reviewed and this review shall be termed as “Final Acceptance Test (FAT)”.
- ii) The review shall include (but not limited to) the required working reliability and performance standards of the equipment to meet tender specifications, the bidder’s responsiveness to resolve all shortcomings mentioned in PAT reports and the bidder’s removal of all pending & outstanding faults or shortages encountered during the Performance Guarantee Period for the Contract. When this FAT becomes due, the bidder shall make an official request to BTCL for starting of the FAT and BTCL shall start the FAT within one month after receipt the request from the bidder.

iii) The contractor shall be responsible for arrangement of all equipment, consumables, test tools and measuring equipment required (if any) for such review tests.

iv) In addition, the contractor has to provide per-diem costs to FAT engineers as per following :

- a) Number of members of FAT team : 15 (Fifteen)
- b) Max. number of man-day/endpoint (site) (excluding central site) : 2 (Two)
- c) Maximum number of man-day for central site : 5 (Five)
- d) Per diem charge to FAT members : Tk.1,000/-per man-day

However, the bidder shall note that, if necessary, any or all FAT can continue for more than the above scheduled period; but, in such cases, the bidder shall not be liable to pay per-diem for those additional days. The bidder shall provide local transportation to the FAT Team to conduct the FAT.

7.1.8 Training

a) Orientation for District, Divisional and Central Administration Personnel

The Contractor shall provide orientation training in Bangladesh on the overall systems. The details of the local training shall be as follows:

- a) Number of Officials : 2 (Two) persons/endpoint
- b) Number of minimum working days : 5 (five)
- c) Per diem charge to the officials : BDT 400 (four hundred) per working day per person

The contractor shall arrange the training in batches for convenience. The bidder shall submit detail training proposal including place of training in its offer. However, the place and time of training shall be mutually settled with the contractor.

b) Operation and Maintenance for BTCL personnel

The Contractor shall provide training to BTCL personnel in Bangladesh on the operation and maintenance of the whole system. The details of the local training shall be as follows:

- a) Number of Officials : 12 (Twelve) in total
- b) Number of minimum working days : 7 (Seven) working days
- c) Per diem charge to the officials : BDT 1000 (One thousand) per working day per person

The bidder shall submit detail training proposal including place of training in its offer. However, the place and time of training shall be mutually settled with the contractor.

c) Overseas Training and System Visit

The contractor shall arrange a training program in an overseas country (within Asia) for the officers and engineers on the overall video conference system operation, management and usage procedures & policy. The training program must include a practical site visit of video conferencing system setup consisting of equipment of the offered manufacturer. The details of the overseas training and system visit shall be as follows:

- a) Number of Officials : 7 (Seven)

-
- b) Number of minimum working days : 10 (Ten) working days
c) Per diem charge to the officials : US\$ 60 (Sixty) per day (*including holidays in between and travel days*) per person
d) Other facilities : Local Transportation
Standard Accommodation
Economy Class Return Air Ticket
Medical Services (*if required*)

The bidder shall submit detail training proposal including place(s) of training and site visit in its offer.

7.1.9 Last Mile Connectivity and Power Connection

BTCL has already established last mile connectivity through laying dark optical fiber cable from BTCL exchange node to video conferencing endpoints. BTCL will also arrange to provide dedicated bandwidth between the nodes of the network. The successful contractor will be provided AC/DC connection point. Further wiring, distribution for Video conferencing Equipments has to be provided by Successful bidder.

7.1.10 Installation and Commissioning Services

The Bidder shall be responsible to provide all materials and services related to installation, configuration, testing, commissioning and cut-over services for all equipment covered by this purchase.

7.1.11 Survey, Network Planning & Design Services

- i) As part of its turn-key responsibility, the **successful bidder** shall be responsible to provide all services related to installation survey, planning & final design of the network.
- ii) A report shall be submitted to BTCL's relevant office after completion of that work.

7.1.12 Documentation

The **successful bidder** shall supply at least (but not limited to) the following documents before PAT of each site.

Technical documentation for all equipment of each site in hard copy (two sets) and 1(one) set in CD ROM. Such document shall include (but not limited to) the following:

- i) System description
- ii) Input/ command manual & output manual with detail explanation of each parameter
- iv) Operation and Maintenance manual/ Standard Operating Procedure
- v) As-built installation and configuration drawings for all equipment
- vi) Detail technical document for NMS
- vii) PAT documents for each site

7.1.13 Mentioning additional equipment

If the bidder thinks that any additional equipment, not listed in this document, is needed for proper implementation and subsequent O&M of the proposed equipment, he shall mention such equipment in the relevant form.

7.1.14 Possibility of change in Scope of Work and BoQ

The Bidder shall consider that, the capacity, number and location of nodes and other equipment and subsequently the total BoQ may change, depending upon the actual requirement during BoQ preparation with the successful bidder.

7.1.15 Room Renovation

Bidder shall be provided room/space to install all the equipments at all endpoints and central site. The renovation, if required, shall be done upon discussion with the contractor by BTCL.

7.2 Technical Specifications of VC Equipments for End Points

7.2.1 VC Equipment for High End User

7.2.1.1 The system shall be supplied with wide flat screen LCD display unit, wireless remote control, HD camera, microphone, digital audio module, integrated speaker and integrated floor stand wheel base. **Separate Trolley is not acceptable for high end user.** The camera should be detachable so that it can be placed as per the desired location of the display unit. The system shall have backup audio call facility in case of failure of the video call.

Any deviation shall be treated as “Major Deviation.”

7.2.1.2 Camera Specifications:

- 720p30 pan/tilt/zoom
- Resolution: min 1280 x 720p 30fps
- At least 10x Optical Zoom

Any or many deviation(s) shall earn penalty point equivalent to ONE “Major Deviation.”

- Wide Angle zoom lens with minimum 70 degree field of view
- Far-end camera control
- Automatic or manual focus/brightness/white balance

Each deviation shall earn penalty point equivalent to ONE “Minor Deviation.”

- Camera and codec should have a split form factor and should be from the same manufacturer

Deviation shall be treated as “Critical Deviation.”

7.2.1.3 Video resolution support:

- 16:9 Mode (Widescreen)
- For Native PC Resolutions:
 - XGA (1024 x 768)
 - SVGA (800 x 600 pixels)
 - VGA (640 x 480 pixels)

Each deviation shall be treated as “Minor Deviation.”

The offered system should support the following resolutions video resolution.

-
- Up to 1080p
 - 4CIF/4SIF
 - Interlaced CIF
 - CIF/SIF
 - QCIF/QSIF

Each deviation shall be treated as “Major Deviation.”

7.2.1.4 Bandwidth

- Support for bandwidth less than or equal to 6 Mbps (point-point high end user) - H.323, SIP

Deviation shall be treated as “Major Deviation.”

7.2.1.5 Video Standards

- H.261,H.263, H.263+/H.263++, H.264, and H.239 compliant

Any Deviation shall be treated as “Major Deviation.”

7.2.1.6 Video Inputs and Output

- Min 1 HD Video input (720p30) and 1 DVI-I (VGA enabled)
- Minimum 2 HD Output (720p at 30 frame/second)

Each deviation shall be treated as “Minor Deviation.”

7.2.1.7 Audio Standards

- At least G.711, G.722, G.722.1C,G.728, MPEG-4 AAC-LD or equivalent or better

Any deviation shall be treated as “Minor Deviation.”

7.2.1.8 Audio Inputs

- Minimum 1 x Mic input
- Minimum 1 x audio port for PC audio

Each deviation shall be treated as “Minor Deviation.”

7.2.1.9 Audio Output

- Minimum 1 for digital MAIN output
- Minimum 1 x audio port for external sound box

Each deviation shall be treated as “Minor Deviation.”

7.2.1.10 Audio Features

- CD-Quality - Mono and Stereo audio
- Acoustic echo cancellation facility
- Automatic Gain Control (AGC)
- Automatic Noise Reduction

Each deviation shall be treated as “Minor Deviation.”

7.2.1.11 Directory and Address Book

-
- LDAP support/H.350 support
 - Minimum 200 local directory entry supports.

Each deviation shall be treated as “Minor Deviation.”

7.2.1.12 Interfaces

- Wireless remote control
- Graphical user interface
- Network interface – 10/100 Base T Ethernet

Each deviation shall be treated as “Major Deviation.”

7.2.1.13 Power Supply Options

- Power supply: AC 170~240V , 50 Hz

Deviation shall be treated as “Major Deviation.”

7.2.1.14 Display Unit:

The display unit may preferably be integrated with the system from the same manufacturer having minimum 50” large-screen LCD. The bidder may also quote display unit from other renowned vendor as per following specification.

- **Large-screen LCD**
- Screen size – 50” (127 cm) diagonal
- Widescreen resolution – 1920 x 1080p pixel HDTV and a wide 16:9
- 50-Hz video signal input
- 600 Hz Sub-field Drive Intelligent Frame Creation for full HD
- Contrast ratio infinite black with over 2,000,000:1 Dynamic Contrast (Native 40,000:1)
- Photo sensor to measures room ambient light and automatically adjust picture setting
- Protective glass layer to absorb impact resistance of display panel
- Wide viewing angle of 178°
- Swivel Angle on stand ±10°
- Power supply: AC 170~240V, 50 Hz

Any or many deviation(s) shall earn penalty point equivalent to ONE “Minor Deviation.”

7.2.2 VC Equipment for Standard User

7.2.2.1 The system shall include Video conferencing codec unit, camera, display unit and audio equipment. The system shall be a high definition videoconferencing system that supports point-point video calls with backup audio call facility in case of failure of the video call. VC Equipment for Standard User shall be from the same manufacturer of Equipment for High End User.

Any deviation shall be treated as “Major Deviation.”

7.2.2.2 Camera

- 720p30 pan/tilt/zoom
- Zoom- Optical Zoom-10x or more
- Resolution: at least 1280 x 720 pixels, 30fps

Any or many deviation(s) shall earn penalty point equivalent to ONE “Major Deviation.”

- Horizontal field of view minimum 70 Degree
- Automatic or manual focus/brightness/white balance
- Far-end camera control

Each deviation shall earn penalty point equivalent to ONE “Minor Deviation.”

- Camera and codec should have a split form factor and should be from the same manufacturer

Deviation shall be treated as “Critical Deviation.”

7.2.2.3 Video resolution

- 16:9 Mode (Widescreen)

The offered system should support the following video resolutions.

- Up to 720p
- 4CIF/4SIF
- Interlaced CIF
- CIF/SIF
- QCIF/QSIF

Each Deviation shall be treated as “Major Deviation.”

7.2.2.4 Bandwidth

- Should support bandwidth less than or equal to 6 Mbps for point-to-point call with H.323,/SIP

Deviation shall be treated as “Major Deviation.”

7.2.2.5 Video Standards

- H.261, H.263, H.263+, H.264

Any Deviation shall be treated as “Major Deviation.”

7.2.2.6 Video Inputs and Outputs

- Minimum 1 HD Video input (HDMI) & 1 DVI/VGA input
- Minimum 1 HD Output (720p at 30 frame/second)

Each Deviation shall be treated as “Major Deviation.”

7.2.2.7 Audio Standards

- At least G.711, G.722, G.722.1C, G.728, MPEG-4 AAC-LD or equivalent or better

Any deviation shall be treated as “Minor Deviation.”

7.2.2.8 Audio Inputs

- Minimum 1 x Mic input
- Minimum 1 x audio port for PC audio

Each deviation shall be treated as “Minor Deviation.”

7.2.2.9 Audio Output

- Minimum 1 for digital MAIN output
- Minimum 1 x audio port for external sound box

Each deviation shall be treated as “Minor Deviation.”

7.2.2.10 Directory and Address Book

- Auto Discovery of endpoints and population of directory
- Minimum 200 local directory entry support.

Each deviation shall be treated as “Minor Deviation.”

7.2.2.11 Interface

- Wireless remote control
- Graphical user interface
- Web Browser based GUI access
- Network interface – 10/100 BaseT Ethernet

Each deviation shall be treated as “Major Deviation.”

7.2.2.12 Power Supply Options

- Power supply: AC 170~240V, 50 Hz

Deviation shall be treated as “Major Deviation.”

7.2.2.13 Display Unit

The display unit may preferably be integrated with the system from the same manufacturer having minimum 42” large-screen LCD. The bidder may also quote display unit from other renowned vendor as per following specification.

- Large-screen LCD
- Screen size – 46” (116 cm) diagonal
- Widescreen resolution – 1920 x 1080p pixel HDTV and a wide 16:9
- 50-Hz video signal input
- 200 Hz Frame Creation for full HD
- Contrast ratio 50,000:1 with brightness 500 cd/m²
- Response time (GTG) 4 ms
- Wide viewing angle of 178°
- Swivel Angle on stand ±10°
- Power supply: AC 170~240V, 50 Hz

Any or many deviation(s) shall earn penalty point equivalent to ONE “Minor Deviation.”

7.2.3 PC/Laptop User

7.2.3.1 PC/Laptops should have desk top client installed and be able to participate in an ongoing conference using his web camera and audio facilities. The software should support intuitive user interface with presence capability that indicates when users are available.

The software should be from same manufacturer of Video endpoints, MCU, Management solution, Recording and content management solution. The solution should support at least 75 desktop clients so that video, voice, content can be availed by the users in the network. The software upgrade notification for any new releases should be available to the PC client from the management application. Deviations shall be treated as **“Major Deviation.”**

7.2.3.2 Video Features:

- The desktop clients should be capable of transmit HD and receive HD video when in a point to point call between two PC's , point to point call between a PC and Videoconferencing system and Multipoint call on the MCU.
- The desktop client must also be able to share content at anytime during a call either with another client or with hardware based endpoint.
- Full Screen View should be possible for a Video call from a desktop client

Each deviation shall be treated as “Minor Deviation.”

7.2.3.3 Audio Features:

- Adaptive acoustic echo cancellation
- Perceptually optimized packet loss concealment

Each deviation shall be treated as “Minor Deviation.”

7.2.3.4 User Interface:

- Address book search
- My Contacts
- Recent calls with time, date and duration
- Bandwidth settings control
- Resolution settings control

Each deviation shall be treated as “Minor Deviation.”

7.2.4 In each High End user location, there will be there display screens- two 50” HD LCD display unit and one 120” projector screen. The bidder shall arrange to accommodate the pictures of all the participants of the ongoing conference in these three screens in all possible combinations. The bidder shall quote for any hardware and/or software in the relevant form, if required, to fulfill this requirement.

Deviation shall be treated as “Major Deviation.”

7.3 Technical Specifications of Multi-point Control Unit

7.3.1 The MCU shall have a built-in auto-attendant from which users can select conferences to join or start a new conference. This shall be operated using either DTMF or Far End Camera Control (FECC) commands. MCU must support a configurable ‘Text Overlay’ features, optionally displaying the party H.323 ID, or custom text, within the video frame during continuous presence or voice activated switching.

7.3.2 All components of the Video Conferencing solution – End equipment for Standard users, MCU, Scheduling, Reporting and Management System, Communication Server, Streaming, Content and Recording System and desktop client software shall be from the same manufacturer. It

should again be mentioned that display manufactured by other renowned manufacturer may be offered. **Deviation shall be treated as “Major Deviation.”**

7.3.3 The MCU shall have the following minimum capacity:

	Location	No. of video port @ 720p HD	Number of concurrent connections
1.	Dhaka	30	12
2.	Chittagong	16	8
3.	Khulna	16	8
4.	Barisal	12	6
5.	Rajshahi	12	6
6.	Rangpor	12	6
7.	Sylhet	12	6

- All MCU should additionally support audio ports on IP as same number of video port mentioned

Each deviation shall be treated as “Major Deviation.”

7.3.4.1 Bandwidth

- MCU shall support a bandwidth less than or equal to 6 Mb/s per port with both H.263 and H.264 in all conference modes.

Each deviation shall be treated as “Major Deviation.”

7.3.4.2 MCU Management

- The MCU shall provide a built-in Web server for configuration and administration and should also support client based plug-in for login.
- The MCU shall support multiple access levels/ user privileges from administrator to simple guest
- The MCU shall support a predefined and unique PIN for each conference

Each deviation shall be treated as “Minor Deviation.”

7.3.5 Other technical specifications

- The MCU must support a mix of resolutions in both Voice Activated mode and Continuous Presence.
- The MCU shall interoperate with multiple vendors’ endpoints
- The MCU shall support down-speeding and packet error/loss concealment methods to ensure optimum video and audio quality.

Each deviation shall be treated as “Minor Deviation.”

7.3.6 Audio Protocols

- At least G.711, G.722, G.722.1C, G.728, MPEG-4 AAC-LD or equivalent or better

Any deviation shall be treated as “Minor Deviation.”

7.3.7 Video Protocols

- Shall support the video standards: H.261, H.263, and H.264

-
- Shall support video resolutions from QCIF to 720p

Each deviation shall be treated as “Minor Deviation.”

7.3.8 MCU Chair Control

- H.243 Chair control functions for conference management by a terminal endpoint
- Conference control using DTMF/GUI Control functions like invite, terminate conference, take or release chair control, mute, volume control, video layout change and block or unblock admission to a conference.

Each deviation shall be treated as “Minor Deviation.”

7.3.9 Data Support

- H.239 or Duo-Video standards for sending/receiving multiple streams of video and presentation content.

Any deviation shall be treated as “Major Deviation.”

7.3.10 MCU Video CP Layout

- Layout choices at least 23 different layouts or a full screen.
- Configurable to adapt the continuous presence screen layouts to accommodate newly added or dropped participants from the conference.
- The solution shall support Standard Definition and High Definition in both Voice Activated and Continuous Presence mode without loss of functionality or capacity

Each deviation shall be treated as “Minor Deviation.”

7.3.11 Network Interface

- Shall have at least one 10/100 Mbps full duplex auto sensing RJ45 Ethernet interface.

Any deviation shall be treated as “Major Deviation.”

7.3.12 MCU Other Features

- Support conference dial out and dial in
- Support lecture and presentation mode
- Support HTTP, HTTPS
- MCU must support Quality of Service (QOS)

Each deviation shall be treated as “Minor Deviation.”

7.3.13 Power Supply Options

- Power supply: AC 170~240V, 50 Hz

Any deviation shall be treated as “Major Deviation.”

7.4 Communication Server

7.4.1 The Communication Server shall provide gatekeeper services, firewall and call control services. The communication server shall work as the center of the intelligent video communication network, connecting all infrastructures, management and endpoint devices. The system should provide standards-based and secure firewall traversal for SIP or H.323 devices and enables communication with the outside world.

7.4.2 The system should be integrated hardware solution and 19” rack-mount size. It should be from same manufacturer of video endpoints, MCU, Scheduling, Management and Reporting System, Content, Streaming and Recording system. However, the services may be integrated in a single system/hardware or the bidder may offer separate system/hardware for different services.

Any deviation shall be treated as “Major Deviation.”

7.4.3 The system shall support the following features:

- The system must support a PC-based application for communicating over video and voice with content sharing
- H.323 gatekeeper (Control Application)
- SIP Proxy/H.323 Registrar (Control Application) for desktop software based clients
- SIP/H.323 support, including SIP/H.323 gatewaying for locally registered endpoints
- SIP/H.323 gatewaying for non-registered endpoints
- Minimum 100 registrations (scalable to support 400 registrations) and 10 concurrent calls.
- Flexible zone configuration with prefix, suffix and regular expression support
- Gatekeepers or SIP proxies
- IPv4 and IPv6 support, including IPv4/IPv6 gatewaying
- Bandwidth management on both a per-call and a total usage basis, configurable separately for calls within the local subzones and to neighboring systems and zones
- Endpoint authentication

Each deviation shall be treated as “Minor Deviation.”

7.4.4 Call Control and Registrations Functions

- Supports manual registration of H.323/SIP endpoints and API call control
- Supports H.225/Q.931, H.245 call control routed mode
- Supports H.323/SIP Inter working Dual Video
- Registration of H.323 ID, E.164 aliases and services

Each deviation shall be treated as “Minor Deviation.”

7.4.5 Bandwidth Management

- Inter-zone: definable call by call:
 - Max bandwidth per call
 - Max aggregate bandwidth for all neighboring zones
- Intra-zone: definable call by call:
 - Max bandwidth per call
 - Max aggregate bandwidth

Any or many deviation(s) shall be treated as ONE “Minor Deviation.”

7.4.6 Firewall Function

-
- The system should provides standards-based and secure firewall traversal for SIP/H.323 devices and enables communication with the outside world.
 - NAT Traversal functionality enabling secure traversal of any NAT firewall
 - Registration of traversal-enabled endpoints

Any or many deviation(s) shall earn penalty point equivalent to ONE “Major Deviation.”

7.4.7 Management Function

- Supports industry standards such as RS-232, Telnet, and HTTP(S)
- Embedded setup wizard on serial port for initial configuration

Each deviation shall be treated as “Minor Deviation.”

7.4.8 Interfaces

- 10/100/1000 Base-TX Ethernet ports (RJ-45)

Deviation shall earn penalty point equivalent to ONE “Major Deviation.”

7.4.9 Power Supply Options

- Power supply: AC 170 ~ 240V , 50 Hz

Deviation shall earn penalty point equivalent to ONE “Major Deviation.”

7.5 Network Operation and Management System

7.5.1 Content, Streaming and Recording Server

7.5.1.1 The system should be able to store different useful contents required for presentation time-to-time in the meeting. This content will be accessible to the user during meeting. It should be from same manufacturer of Video endpoints, MCU, and Management system.

The purpose of the Content and Recording Server is to share knowledge and enhance communication by capturing any video-conference recording, access live and on-demand presentations, content and documentations anywhere, anytime and distribute live or recorded content to any computer.

7.5.1.2 The system should have inbuilt storage capacity for minimum 500 hrs content @ HD 720p @30fps. The system must be able to configure minimum 5 numbers of concurrent simultaneous call recording and minimum 1 of which can be streamed live.

Any deviation shall earn penalty point equivalent to ONE “Major Deviation.”

7.5.1.3 Recording Features

- Pre-defined template-based recording options
- Full flexibility through built-in Web-based Template Editor
- Record presentations or video from live dual stream
- Supports H.323 endpoints and MCUs
- Calls may include main video/audio and H.239/Duo

Each deviation shall be treated as “Minor Deviation.”

7.5.1.4 Content Library Features

- Searchable content library web interface
- View live and recorded content through Content Viewer web interface
- Simplified graphical Template Editor for easy creation of new recording templates
- Content Editor enables trimming and joining conferences using playlists
- Supports major web browsers

Each deviation shall be treated as “Minor Deviation.”

7.5.1.5 Video Standards

- H.261, H.263, H.263+, H.264

Each deviation shall be treated as “Minor Deviation.”

7.5.1.6 Audio Standards

- At least G.711, G.722, G.722.1C, G.728, MPEG-4 AAC-LD or equivalent or better

Any or many deviation(s) shall be treated as “Minor Deviation.”

7.5.1.7 Live and On-Demand Streaming

- Min 1 call can be streamed live
- Embedded Native Windows Media Streaming Server

Each deviation shall be treated as “Minor Deviation.”

7.5.1.8 Live Video Resolutions

- Up to HD 720p (1280x720)

Each deviation shall be treated as “Minor Deviation.”

7.5.1.9 Security Features

- Secure management via HTTPS
- Integration with Active Directory for access database backup and restore utility included
- Password protected streaming content playback

Each deviation shall be treated as “Minor Deviation.”

7.5.1.10 Interfaces

- 10/100/1000 Base-TX Ethernet ports (RJ-45)

Any deviation shall earn penalty point equivalent to ONE “Major Deviation.”

7.5.1.11 Power Supply

- Power supply: AC 170~ 240 V, 50 Hz

Any deviation shall earn penalty point equivalent to ONE “Major Deviation.”

7.5.1.12 Physical Dimension

- 19” rack-mount chassis

Any deviation shall earn penalty point equivalent to ONE “Major Deviation.”

7.5.2 Management, Scheduling and Reporting System

7.5.2.1 Management, Scheduling and Reporting system shall provide complete visibility and control of the network on-site and remotely. The Management, Scheduling and Reporting system shall be a pre-installed server, support for all the Video terminals and MCU in the network, as per the quantities stated in the BOQ. The system to be provided with a common network management system based on SNMP with user friendly GUI for both the MCU and video end points.

7.5.2.2 Scheduling, Network Management and Reporting System shall be from the same manufacturer of all other components of the Video Conferencing solution i.e. End equipment (High End and Standard), MCU, Communication, Content, Streaming & Recording System and desktop client software. **Any deviation shall be treated as “Critical Deviation.”**

7.5.2.3 It should have the following features as a minimum –

- The system to be provided with a common network management system based on SNMP.
- Network Management software supporting the following functionality:
 - Network status updates: MCU elements, end point information, error status.
 - Communication view: MCU controlling the communication, communication type, video and bandwidth settings, number of participants
- The management software must capture CDR's, diagnostics, faults, alarms

Each deviation shall be treated as “Minor Deviation.”

7.5.2.4 Communication Control Center

- The management application should support device registration for minimum 100 devices
- Complete communication overview on one screen

Each deviation shall be treated as “Minor Deviation.”

7.5.2.5 System Control

- Phonebook access
- Software upgrades
- Change video layouts
- Volume control and audio mute/unmute
- Microphone on/off
- Edit local phone books

Each deviation shall be treated as “Minor Deviation.”

7.5.2.6 Event Notification

- Event Notification shall be integrated into any SNMP Network Management system
- Down speeding, upgrade start/finish scheduling, gatekeeper registration, low battery, wrong password alert

Each deviation shall be treated as “Minor Deviation.”

7.5.2.7 Scheduling and Booking

- Book recurring meetings and video resources
- Create, password protect, edit or delete booked communications
- Add/remove participants from reservation or connect/disconnect participants during communications
- Lock communication, preventing new participants from joining

Each deviation shall be treated as “Minor Deviation.”

7.5.2.8 Reporting

- Support for multiple reporting formats: Onscreen, PDF or HTML
- Number of incoming and outgoing calls
- Number/address called
- Authentication failure
- Error statistics

Each deviation shall be treated as “Minor Deviation.”

7.5.2.9 Interfaces

- 10/100/1000 Base-TX Ethernet ports (RJ-45)

Any deviation shall be treated as “Major Deviation.”

7.5.2.10 Power Supply

- Power supply: AC 170~240 V, 50 Hz

Any deviation shall be treated as “Major Deviation.”

7.5.2.12 Physical Dimension

- 19” rack-mount chassis

Any deviation shall be treated as “Major Deviation.”

7.5.3 The servers shall be supplied with standard 19” rack preferably manufactured by system manufacturer. The devices like MCU, Communications server, Management and Scheduling, Recording and streaming device etc. should be from the same OEM, must be hardware based, rack mountable and should be provided with all the necessary licenses, cables, CDs, Manuals etc. In case of multiple hardware servers, the bidder may arrange necessary hardware (like KVM switch) so that administrator can work using single 17” LCD Monitor, Keyboard and Mouse.

7.5.4 Management Terminal

The bidder shall provide four management terminals to be installed at Dhaka central site with necessary management software for operation and managing the network (configuring any network equipment, trouble shooting etc). Among the four terminals two will be desktop and two will be portable. The minimum specifications of the terminals are described below:

Desktop Terminal:

Brand	: Any International Reputed Brand
Processor	: Intel Core 2 Quad-Core, 2.66 GHz
RAM	: 2 GB
Hard Disk	: 320 GB
DVD-Writer	: 22X Dual DVD R-RW
Monitor	: 17” LCD Monitor
Operating System	: Original Windows XP or Windows 7 with license
Keyboard	: Multimedia Keyboard
Mouse	: Optical Scroll

Each deviation shall earn penalty point equivalent to ONE “Minor Deviation.”

Portable Terminal:

Brand	: Any International Reputed Brand
Processor	: Intel Core 2 Duo, 2.20 GHz
RAM	: 2GB
Hard Disk	: 320 GB
DVD-Writer	: DVD RW
Monitor	: 13.3” TFT or higher technology
Network Adapter	: 10/100 Ethernet, Wireless LAN and Bluetooth
Operating System	: Original Windows XP or Windows 7 with license

Each deviation shall earn penalty point equivalent to ONE “Minor Deviation.”

7.6 Technical Specifications of Networking Equipment

7.6.1 Central Router

The Central Router shall have the following general characteristics.

7.6.1.1 Connectivity

- a) The Router shall support Packet over Synchronous Optical Network (POS), Gigabit/Fast Ethernet, and Channelized STM-1 interface types.
- b) All the interface mentioned above shall be supported in the same chassis offered in the bid.

Any or many negative deviation(s) shall earn a penalty point equivalent to ONE “Critical Deviation.”

7.6.1.2 Management

The management of the Router shall support the following:

- i) Command Line Interface (CLI)
- ii) Extensive Simple Network Management protocol (SNMP) support

Any or many negative deviation(s) shall earn a penalty point equivalent to ONE “Critical Deviation.”

7.6.1.3 General IP Features

The Router shall be able to support the following general IP features.

- a. Internet Protocol- RFC 791
- b. Internet Control Message Protocol (ICMP) – RFC 792
- c. IP Multicast
 - i) Internet Group Management Protocol (IGMP) – RFC 1112
 - ii) PIM dense mode, PIM sparse mode
 - iii) Multicasting BGP (MBGP)
- d. User Datagram Protocol (UDP) – RFC 768
- e. Transmission Control Protocol (TCP) – RFC 793

-
- f. Requirements for IPv4 Routers – RFC 1812
 - g. Telnet Protocol Specification – RFC 854
 - h. Network Timing Protocol (NTP) – RFC 1305
 - i. DHCP

Any or many deviation(s) shall earn penalty point equivalent to ONE “Major Deviation.”

7.6.1.4 The Router shall support the following protocols from the day one.

- a. PPP
- b. HDLC
- c. Multi-link PPP
- d. Link Bundling for high speed links
- e. Equal load sharing on all high speed links
- f. Network Address Translation
- g. IP header Compression
- h. Compressed RTP (cRTP)
- i. GRE VPN

Any or many deviation(s) shall earn penalty point equivalent to ONE “Major Deviation.”

7.6.1.5 Routing

The routing features shall include the following.

- a. Static Routing
- b. The BGP Features to be supported are:
 - i. RFC1771 & 1772, BGPv4
 - ii. RFC1997, BGP Communities Attribute
 - iii. RFC 2270: Using a Dedicated AS for Sites Homed to a Single Provider.
 - iv. RFC 2385: Protection of BGP Session via the TCP MD5 Signature Option.
 - v. RFC 2439, BGP Route Flap Damping
 - vi. RFC 2796, BGP Route Reflection – An Alternative to Full Mesh IBGP
 - vii. RFC 2918, Route Refresh Capability for BGP-4
 - viii. RFC 3065, Autonomous System Confederations for BGP
 - ix. RFC 3107, Carrying Label Information in BGP-4
 - x. BGP Extended Communities Attribute
- c. The router shall support following OSPF protocol features:
 - i. OSPF V2 as per RFC 2328
 - ii. RFC1403, BGP-OSPF interaction
 - iii. OSPF Not So Stubby Area (NSSA) RFC 3101
 - iv. RFC1850, OSPFv2 MIB
 - v. RFC2370, Opaque LSA option
 - vi. RFC 2740, OSPF for IPv6
 - vii. OSPF Stub Area
 - viii. Traffic Engineering (TE) extensions to OSPF v2 (OSPF-TE) as per RFC 3630.
 - ix. OSPF graceful restart
- d. RIPv1 and RIPv2
- e. IS-IS
- f. MPLS

Any or many deviation(s) shall earn penalty point equivalent to ONE “Major Deviation.”

7.6.1.6 The router shall support the following MPLS/VPN features.

-
- i. MPLS RFC 2547bis MPLS L3 VPN
 - ii. MPLS E-LSP and MPLS Fast Re-Route
 - iii. MPLS L2 VPN (Ethernet, VLAN, FR, PPP, HDLC, ATM over MPLS)
 - iv. The router shall support 1000 VRF
 - v. Scheduling/ queuing for 8 classes that provide configurable minimum bandwidth allocation to each class, based on 802.1p and IP TOS bits.
 - vi. Mapping of 802.1p and IP TOS bits into MPLS EXP bits.
 - vii. The router shall support mapping of 802.1q VLAN tags into MPLS labels.
 - viii. RFC 3031, Multi-protocol Label Switching Architecture
 - ix. RFC 3032, MPLS Label Stack Encoding
 - x. LDP specification as per RFC 3036.
 - xi. RFC 3270, Multi-Protocol Label Switching (MPLS) Support of Differentiated Services
 - xii. RFC 3443, Time To Live (TTL) Processing in Multi-Protocol Label Switching (MPLS) Networks
 - xiii. RFC 3469, Framework for Multi-Protocol Label Switching (MPLS)-based Recovery
 - xiv. Dynamic MPLS LSP setup with signaling protocol shall be supported on all the router interfaces.
 - xv. The router shall support LSP Ping, LSP Trace route and L2VPN OAM functionalities.

Each deviation shall be treated as Minor Deviation.”

7.6.1.7 An essential feature for Router is to support differentiated Quality of Service (QoS) for IP packets. The router must be able to deliver the following IP QoS to allow service providers to offer differentiated IP service plans to their subscribers.

- i. Simple traffic classification (DSCP or TOS bits). The router shall support Low latency-Low Jitter for VOIP Class of service in addition to Assured Services and Best effort services.
- ii. Traffic Control
- iii. Traffic shaping
- iv. Congestion control based on Weighted Fair Queuing
- v. Congestion avoidance based on RED and Weighted RED
- vi. Support of DiffServ

Each deviation shall be treated as Minor Deviation.”

7.6.1.8 Other High Availability Feature Support required from day one

- a) Virtual Router Redundancy Protocol (VRRP)
- b) Bi directional Failure Detection (BFD)
- c) Graceful Restart and Non Stop forwarding for BGP, OSPF, ISIS
- d) 50ms switchover in case of node failure on an IP forwarding network

Any or many deviation(s) shall earn a penalty point equivalent to ONE “Major Deviation.”

7.6.1.9 The Router shall provide the following security features.

7.6.1.9.1 Equipment Security

- a) Ensuring hierarchical user authorities, preventing unauthorized configuration of equipment
- b) Providing SSH, ensuring security for administrator accounts

-
- c) Supporting the application of complex ACL policies on host ports, preventing illegal access to the equipment

Any or many deviation(s) shall earn penalty point equivalent to ONE “Major Deviation.”

7.6.1.9.2 Protocol Security

- a) Supporting plain text authentication and MD5 authentication for common routing protocols, avoiding importing invalid routing information
- b) Supporting SNMP V3

Any or many deviation(s) shall earn penalty point equivalent to ONE “Major Deviation.”

7.6.1.9.3 Hardware configuration and Performance Requirement

The Router shall have the following capabilities.

- a) The backplane capacity shall be not less than 1.8 Gbps
- b) The Router shall support the forwarding rate of minimum of 2 million packet per second.
- c) The router shall have at least 2 (1+1) redundant DC power supply (-48V).
- d) All interface modules shall support hot swapping.
- e) Must support IPv6
- f) The Router Processor shall be supplied with minimum of 1 GB DRAM and 32 MB Flash memory expandable to 2 GB DRAM and 256 MB Flash memory.

Any or many deviation(s) shall earn a penalty point equivalent to ONE “Critical Deviation.”

7.6.1.10 Present and Final interface capacities

The present equipped interface capacity shall be at least 4 Gigabit Ethernet ports. There shall be at least one slot free for future expansion.

Any deviation shall be treated as “Critical Deviation.”

7.6.2 Specification of Central LAN switch (Type-I)

Central LAN switch (Type-I) shall be Metro Ethernet Forum (MEF) certified. **Any deviation shall be treated as “Critical Deviation.”** The certification may be verified by visiting Metro Ethernet Forum’s web site. The Central LAN Switch (Type-I) shall have the following general characteristics.

7.6.2.1 General Features.

- a. The broadcast storm suppression is to suppress the flooding of the unknown unicast, multicast, and broadcast packets on the network, thereby bating the affect of packet upon the network efficiency.
- b. The system shall support 4096VLAN transport.
- c. Multiple Spanning Tree Protocol (MSTP) as per 802.1S
- d. IEEE 802.1W Rapid Spanning Tree (RSTP)
- e. The system shall support IP version 6 in addition to IP Version 4
- f. The system shall support Policing and shaping the traffic with 32Kbps granularity.
- g. The system shall support minimum of 128MB RAM and 32MB Flash

-
- h. The switch shall support different type of optical modules which shall include 2KM, 10KM and 40KM distance support. Also it shall support 10/100/1000TX.
 - i. Support of 802.1q Trunking
 - j. The system shall support User configurable Management VLAN.
 - k. The System shall support Port mirroring for Traffic analysis or Security Monitoring.

Any or many deviation(s) shall earn penalty point equivalent to ONE “Major Deviation.”

7.6.2.2 Network Protocol Feature

- a. Address Resolution Protocol (ARP)
- b. Dynamic Host Configuration Protocol (DHCP) Relay
- c. The switch shall support minimum of 8000 Mac address
- d. The system shall learn the MAC address using static commands or dynamic
- e. All ports shall work on either Half or Full duplex. The System shall support manual or auto negotiation feature for defining the Half or Full Duplex mode of operation.
- f. Should generate Syslog and SNMP trap for all the events

Any or many deviation(s) shall earn penalty point equivalent to ONE “Major Deviation.”

7.6.2.3 Routing Feature

- a. Static Route and Default Route
- b. Open Shortest Path First (OSPF)
- c. RIP version-1 and 2
- d. Border Gateway Protocol (BGP)
- e. Multicast Features
- f. Internet Group Management Protocol (IGMP) Snooping Version-1, Version-2 and Version-3 shall be supported.
- g. IGMP Filtering shall be supported on both Access and trunk ports
- h. Shall Support transport of Jumbo frames (9K Bytes packet)
- i. Protocol Independent Multicast-Dense Mode (PIM-DM)
- j. Protocol Independent Multicast-Sparse Mode (PIM-SM)

Each deviation shall be treated as Minor Deviation.”

7.6.2.4 Quality of Service (QoS)

- a. QoS is to provide different network services upon different demands.
- b. Traffic Classification and marking based on DSCP or TOS bits
- c. Traffic Policing and Bandwidth Assurance
- d. Traffic Shaping
- e. Port Flow Control
- f. Queue Scheduling
- g. Priority Tag

Each deviation shall be treated as Minor Deviation.”

7.6.2.5 Security Features

- a. Hierarchical management over the users and password protection
- b. Support ACL (Access Control List), Layer 2, 3, and 4 information filter (such as packet filter based on port, source/destination MAC addresses, and packet filter based on source/destination IP addresses and upper layer protocol type).
- c. Support the simple text authentication and MD5 encrypted text authentication for the Routing protocols
- d. Support SNMP V3 encrypted authentication.

-
- e. Packet Filtering
 - f. 802.1X Authentication or Port Based Network Access Control Protocol
 - g. Secured Shell (SSH)

Any or many deviation(s) shall earn penalty point equivalent to ONE “Major Deviation.”

7.6.2.6 Switch (Type-I) Capacity and Configuration

The Central Switch (Type-I) shall be supplied with the following configuration.

- i) The switch shall be supplied with dual (1+1) -48V DC power supply module for redundancy.
- ii) The Switch shall support minimum of 120Gbps of switch capacity and 100 million packets per second forwarding performance.
- iii) The switch shall be supplied with 128 MB RAM and 32 MB flash memory
- iv) The switch shall be supplied with following interface
 - a) Twelve (12) 10/100/1000-TX ports
 - b) Four (4) optical GE with SFP (SX)

Any or many deviation(s) shall earn penalty point equivalent to ONE “Critical Deviation.”

7.6.3 Specification of Type-II LAN Switch

7.6.3.1 The Type-II LAN switch shall support the following features:

- a. The interface protocol provided shall conform to the relevant regulations of IEEE802.3z.
- b. Function L2 and Basic L3 (RIP and static route) Function.
- c. Support optical and electrical interfaces simultaneously.
- d. The Trans-receiver interface (SFP) shall support at least 10 km distance (LX)
- e. Shall have at least four 10/100/1000-T and 12 GE optical port
- f. Equipped with at least 6 GE SFP (LX)
- g. Bandwidth control (Rate limit) with a granularity of at least 64Kbps.

Any or many negative deviation(s) from 7.6.3.1.a to 7.6.3.1.f shall earn a penalty point equivalent to ONE “Critical Deviation.” Any or many negative deviation(s) from 7.6.3.1.g to 7.6.3.1.h shall earn a penalty point equivalent to ONE “Major Deviation.”

7.6.3.2 The Type-II LAN switch shall also support the following features:

- a) Automatic MAC addresses learning and ageing.
- b) MAC entries can be set manually, or learnt dynamically.
- c) Source MAC addresses can be filtered.
- d) Frames can be transferred in unicast, multicast and broadcast mode.
- e) Queues can be scheduled.
- f) Fair algorithm function is provided to guarantee the bandwidth of services.
- g) Shall support the protocols of STP, RSTP and MSTP are all applicable.
- h) Multicast VLAN should be supported and the frames can be duplicated across different VLANs.
- i) Up to 1K multicast groups and 1K user VLANs should be supported.
- j) Transmission rate should be restricted at the outbound port.

Each deviation shall be treated as Minor Deviation.”

7.6.3.3 Traffic shall be classified on the basis of

- a) Source or destination MAC address,
- b) Outbound port and the priority of the frames.
- c) ACL rules.
- d) Customization.

Each deviation shall be treated as Minor Deviation.”

7.6.3.4 QoS should be supported for

- a) The classified packets under the control of ACL.
- b) Traffic policing
- c) Association of Traffic classification and traffic behavior.

Each deviation shall be treated as Minor Deviation.”

7.6.3.5 Power Supply

- Power supply: AC170-240 V, 50 Hz

Any deviation shall earn penalty point equivalent to ONE “Major Deviation.”

7.6.3.6 Physical Condition

- Dimensions: 19-inch rack-mount width

Any deviation shall earn penalty point equivalent to ONE “Major Deviation.”

7.6.4 Specification of Converters

7.6.4.1 Ethernet to E1 converters and Ethernet to E1 converters

7.6.4.1.1 All the Endpoints will be connected to the Divisional VC Node using BTCL’s existing Transmission Network. BTCL has IP nodes at 34 districts. The endpoints of these districts will be provided Ethernet connectivity from the BTCL nearest node through optical fiber. The remaining end points (30 districts) will be connected over existing TDM network using IP over TDM converter. For example, there is no IP node in Chapai Nawabganj. Hence Chapai Nawabganj will be connected to the nearest IP node in Rajshahi through E1 TDM transmission media. For this type of connectivity, a pair of IP/TDM converter will used at both ends. At Rajshahi end, the converter will convert the IP bandwidth at required number of E1(s) and these E1 will be again converted to IP at Chapai Nawabganj end to connect with End points. The links for which IP/TDM converters are required are listed below-

	Endpoints without IP nodes	IP Nodes
1	Kishoreganj	Mymensingh
2	Netrokona	Mymensingh
3	Jamalpur	Sherpur
4	Rajbari	Faridpur
5	Shariatpur	Faridpur
6	Manikganj	Dhaka
7	Munshiganj	Dhaka
8	Khagrachari	Chittagong

9	Bandarban	Chittagong
10	Noakhali	Chittagong
11	Lakshmipur	Chittagong
12	Chandpur	Comilla
13	Narail	Jessore
14	Chuadanga	Kushtia
15	Meherpur	Kushtia
16	Chapai Nawabganj	Rajshahi
17	Natore	Bogra
18	Joypurhat	Bogra
19	Naogaon	Bogra
20	Gaibandha	Rangpur
21	Nilphamari	Rangpur
22	Lalmonirhat	Rangpur
23	Kurigram	Rangpur
24	Thakurgaon	Dinajpur
25	Panchagarh	Dinajpur
26	Pirojpur	Barisal
27	Patuakhali	Barisal
28	Barguna	Barisal
29	Bhola	Barisal
30	Sunamganj	Sylhet

A specific sample case is explained here for better understanding of the scenario. Kishoreganj & Netrokona will be connected with Mymensingh. In this case Bidder may offer two individual converter or one converter (Point to multi points) at Mymensingh end.

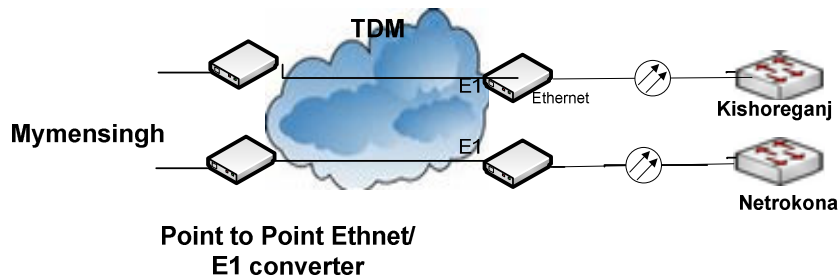
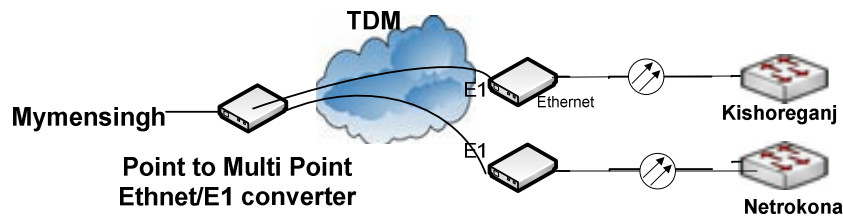

However, for either of the combination bidder has to offer two converters for Kishoreganj & Netrokona sites.

Similarly to connect Khagrachari, Bandarban, Noakhali and Lakshmipur with Chittagong, bidder may offer four individual converters at Chittagong or one converter and so on. **While**

designing converter, bidder has to consider a bandwidth of 4E1 (8 Mbps) for each link.

7.6.4.1.1 Requirement of Ethernet to E1 converter

1. Power : - 48 V DC
2. Ethernet: one Optical GE (SX) and one Electrical GE
Bit Rate: 100 Mbps
Compatibility: IEEE 802.3
3. E1 : Physical port: 75 ohm unbalanced BNC Coaxial Jack (except Chittagong – 120 ohm balanced)
Bit rate: 2.048 Mbps +/- 50 ppm
Compatible with G.703
4. Point to Multi point converter should support Layer -2 VLAN switching

Each deviation shall earn penalty point equivalent to ONE “Minor Deviation.”

7.6.4.1.2 Requirement of E1 to Ethernet Converter

1. Power : - 48 V DC
2. E1 : Physical port: 75 ohm unbalanced BNC Coaxial Jack
Bit rate: 2.048 Mbps +/- 50 ppm
Compatible with G.703
3. Ethernet: Optical GE (LX)
Bit Rate: 1000 Mbps
Compatibility: IEEE 802.3

Each deviation shall earn penalty point equivalent to ONE “Minor Deviation.”

7.6.4.2 Media Converter (Electrical Ethernet to Optical Ethernet)

At Sirajganj, Jhenaidah & Hobiganj IP bandwidth will be delivered from MUX equipment through Electrical RJ45 port. Bidder has to include 3 (three) Electrical Ethernet to Optical Ethernet Media Converters in the offer for these three sites. A typical block diagram with this converter is shown below:

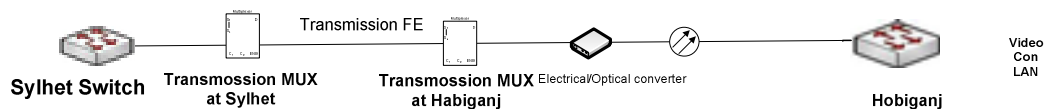

7.6.5 Miscellaneous items like Racks, Optical Distribution Frame (ODF), Multimedia Projector, White Screen etc.

7.6.5.1 Rack/Cabinet:

This rack shall have at least the following features.

- Dimension: around 11 U
- Superior ventilation
- AC fans for cooling
- hole combination rack mount rails
- front glass door (with locking system)
- four leveling feet
- sub distribution board for power including –
 - ground bar x 1
 - AC distribution with 5 Amps MCB x 1, 3-pin flat socket x 2

Any or many deviation(s) shall earn penalty point equivalent to ONE “Minor Deviation.”

7.6.5.2 Optical Distribution Frame ODF

1. The optical distribution / termination frame shall be rack (19 inch. Standard rack) mounted type and will be installed in suitable position in the equipment room.
2. Optical I Links in the optical distribution / termination frame shall be high grade FC/PC type.
3. There shall be easy access for splicing and provision for maintenance facility.
4. There shall be provision for cable entry either from above or from the left hand side, allowing the station cable to enter the bay either from above or below.
5. The capacity of the optical distribution/termination frame shall be minimum of 24 single fibers. The offered optical distribution/termination frame must have adequate space and fixing place for I link (adapter) and will be equipped with necessary Pigtail and I Link for 24 fibers at the beginning. The surplus fibers shall be curled up in splice tray for easy access. The tray shall hold sufficient fiber length to able not only fusion splicing but also reopening and re-splicing of any fiber if needed in futures.
6. There shall be provision for inspection or cleaning the internal fiber connectors.
7. All equipped ports of Type-II switch will have to be terminated to the ODF.

Any or many deviation(s) shall earn penalty point equivalent to ONE “Minor Deviation.”

7.6.5.3 Multimedia Projector

The multimedia projector shall have the following specifications:

1. Type : LCD
2. Image Brightness : 2000 ANSI lumens
3. Contrast Ration : 500:1
4. Native Resolution : 1024 x 768

-
5. Image Size : 24 ~ 300 inch (Diagonal)
 6. Image Aspect Ratio : 4:3 (Standard)
 7. HDTV Format : 720p.1080i
 8. Screen Distance : 3 ft ~ 35 ft
 9. Analog Video Format : NTSC, PAL, SECAM
 10. Audio Output : RCA Jack, 3.5 mm Mini Jack
 11. Video Output : 15 pin D-Sub VGA, Composite Video, 15 Pin D-Sub VGA x 2, S-Video x 1
 12. Interfaces : USB, Mini D-Sub 9 pin x 1
 13. Lamp Type : UHB
 14. Light Source Life : 2000 Hours
 15. Lens shift : Vertical
 16. Projection : Rear, Ceiling

Each deviation shall earn penalty point equivalent to ONE “Minor Deviation.”

7.6.5.4 Projector Screen

Size: 120” (Diagonal)
 Screen Type: Portable
 Aspect Ratio: 4:3
 Viewing Area: 72" x 96"
 Viewing Surface: Matte White

Each deviation shall earn penalty point equivalent to ONE “Minor Deviation.”

7.7 Backup Power Equipment

Online Uninterruptible Power Supply (UPS) will be used as power backup equipment. The UPS shall be high performance for telecommunications, networking equipment and other mission-critical applications. It should deliver precise voltage and frequency regulation, zero transfer time to and from battery, and input power factor correction.

7.7.1 High End User UPS Specification:

- a) Type : **Double Conversion Online**
- b) System Capacity : 5 KVA
- c) Input Voltage : 220 VAC
- d) Output Voltage : 220 VAC
- e) Frequency : 50HZ
- f) Efficiency : Min 85% at rated load
- g) Power factor : > 0.9
- h) Noise : <50dB
- i) Alarm : Low battery condition
: Over load
: Battery dead
- j) Indicator : Over load

- k) Protection : Battery charge
: Battery dead
: Emergency power off
: Lightning and Surge Protection
- l) Backup time : **1 hour at full load**

Each negative deviation from 7.7.1.a), 7.7.1.b), 7.7.1.c), 7.7.1.d), 7.7.1.e), and 7.7.1.l) shall be treated as “Critical Deviation”. Any or many negative deviation(s) from other features as mentioned above shall earn penalty point equivalent to ONE “Major Deviation.” The bidder shall mention the exact brand and model of the UPS and show calculation how the backup time requirement can be met. If the calculation is found to be wrong or not found in the bid, it shall be treated as “Minor Deviation.”

7.7.2 Standard User UPS Specification, Type-1:

- a) Type : **Double Conversion Online**
- b) System Capacity : 2 KVA
- c) Input Voltage : 220 VAC
- d) Output Voltage : 220 VAC
- e) Frequency : 50HZ
- f) Efficiency : Min 85% at rated load
- g) Power factor : > 0.9
- h) Noise : <50dB
- i) Alarm : Low battery condition
: Over load
- j) Indicator : Battery dead
: Over load
: Battery charge
: Battery dead
- k) Protection : Emergency power off
: Lightning and Surge Protection
- l) Backup time : **2 hour at full load**

Each negative deviation from 7.7.2.a), 7.7.2.b), 7.7.2.c), 7.7.2.d), 7.7.2.e), and 7.7.2.l) shall be treated as “Critical Deviation”. Any or many negative deviation(s) from other features as mentioned above shall earn penalty point equivalent to ONE “Major Deviation.” The bidder shall mention the exact brand and model of the UPS and show calculation how the backup time requirement can be met. If the calculation is found to be wrong or not found in the bid, it shall be treated as “Minor Deviation.”

7.7.3 Standard User UPS Specification, Type-2:

- a) Type : **Double Conversion Online**
- b) System Capacity : 2 KVA
- c) Input Voltage : 220 VAC
- d) Output Voltage : 220 VAC
- e) Frequency : 50HZ
- f) Efficiency : Min 85% at rated load
- g) Power factor : > 0.9
- h) Noise : <50dB
- i) Alarm : Low battery condition
: Over load
- j) Indicator : Battery dead
: Over load

-
- | | |
|----------------|----------------------------------|
| | : Battery charge |
| | : Battery dead |
| k) Protection | : Emergency power off |
| | : Lightning and Surge Protection |
| l) Backup time | : 2 hour at full load |

Each negative deviation from 7.7.3.a), 7.7.3.b), 7.7.3.c), 7.7.3.d), 7.7.3.e), and 7.7.3.l) shall be treated as “Critical Deviation”. Any or many negative deviation(s) from other features as mentioned above shall earn penalty point equivalent to ONE “Major Deviation.” The bidder shall mention the exact brand and model of the UPS and show calculation how the backup time requirement can be met. If the calculation is found to be wrong or not found in the bid, it shall be treated as “Minor Deviation.”

- m) The standard user Type-2 UPS shall have the following features so that it can be monitored/managed remotely.
- Connect UPS directly to the network with a dedicated IP address
 - Manage each UPS individually via web browser.
 - Notification features to inform via different means when problems occur.
 - In case of extended power outages graceful shutdown shall be provided to protect the system.

Absence of the remote management facility of Type-2 UPS described above shall be treated as “Major Deviation.” Each deviation of the above remote management feature shall be treated as “Minor Deviation.”

(Letterhead Pad of the Bidder)

Annex-1

Guarantee for Spare Parts

Whereas, we,(name and address of the bidder)....., are submitting our bid "**Installation, Testing and Commissioning of Video Conferencing System for District, Divisional and Central Administrations**" and whereas we understand that as per conditions set in the said tender document, BTCL is in need of a guarantee of continuous supply of spare parts of the equipment we have quoted.

We, therefore, guarantee the flow and availability of all spare parts and units without major design changes for at least 5 (five) years from the issuance of Provisional Acceptance Certificate (PAC) and that, if there is any major design change or stoppage of production, we will bear all the costs related to provision of alternate solutions.

We give further unconditional guarantee that, we will supply all necessary spare parts, software, services, maintenance support and consumables to be used during installation, testing & commissioning and operation of the systems, up to the end of "**Guarantee Period**" at our own cost.

Dated _____ Day of _____ 20 _____.

Name, Signature and seal

Duly authorized to sign for and on behalf of _____

Annex-2

Format for Maintenance Support during Guarantee Period

The Contractor, at his own cost to be quoted during the bid, shall provide the following maintenance supports during the whole Warranty/ Guarantee Period of the Contract:

1. The service shall cover full trouble-shooting and corrective maintenance support for all equipment and sites covered by this purchase.
2. All personnel involved in providing maintenance support must have proper training and must have prior experience in Trouble-shooting, Operation and Maintenance of the relevant systems.
3. The Contractor shall submit the contact details of the persons involved in maintenance support including mobile and fixed telephone numbers, email addresses and escalation hierarchy in terms of number of hours. Contact details can be provided by the successful before starting of guarantee period.
4. The contractor shall be responsible for all types of expenditure to be borne for manpower, including office, overhead, all modes of transportation etc.
5. The services to be provided (but not limited to) shall be :
 - a. Equipping and maintaining an updated inventory of spares and accessories in Dhaka at a premise mutually agreed upon with BTCL. Warehousing cost will be borne by the successful bidder.
 - b. Replacement of faulty cards/ modules/ equipment/ system within the specified time period.
 - c. Regular and required replenishment & updating of the spare & accessories inventory.
 - d. Periodic and Regular checks on the performance of the systems to ensure that they are running in good condition and are not susceptible to any major fault.
 - e. Transfer of technology to BTCL's personnel to enable them to become self-sufficient in fault finding and fault removal.
 - f. Short on-the-job training to BTCL's personnel as and where and when necessary. BTCL will provide Training room only.
 - g. Trouble-shoot and debug any faults occurring in the equipment/ system within the time-period specified in the contract.
 - h. Identify the faulty elements in installation of the system and take actions for rectification.
 - i. Assist BTCL's personnel in subsequent re-installation, re-location of different network elements and other minor works, whenever and wherever desired by BTCL.
 - j. Accompany and assist BTCL's personnel in network performance tests.
 - k. Assist BTCL's personnel in identifying the Key Performance Indicators of the system and take corrective actions for network optimization.
 - l. Help and advice BTCL personnel to properly maintain O&M & CDR data bases and Management of CDRs.
 - m. Regularly inform BTCL of all types of Software and Hardware upgrades of the equipment/ system and suggest actions to be taken by BTCL.
6. The format of the support services to be given by the contractor shall be as follows :
 - a. Chief of the Maintenance support team shall periodically visit the relevant system sites and carry out regular health-checks of the systems.
 - b. On occurrence and/ or detection of any fault to any or many system/ equipment supplied to BTCL's network, under the contract the representative(s) of the first party shall inform the representative(s) of the second party, over telephone, of such fault.

-
- c. All such reports will be logged by both parties, mentioning the time of such reports.
 - d. The personnel of the second party, on being informed by the first party, will attend to any fault in Dhaka site within 02 (two) hours after reporting of the fault. If the fault is reported after 20:00 Hrs or on weekly holidays, the response time can be extended up to 04 (four) hours. On abnormal cases and for occurrences in long holidays, the maximum allowable response time period shall be 12 (twelve) hours from the time of report of fault by the first party.
 - e. For attending any fault outside Dhaka, the reporting time will be maximum 24 (twenty four) hours after reporting of the fault. On abnormal cases and for occurrences in long holidays, the maximum allowable response time period shall be 48 (forty eight) hours from the time of report of fault by the first party.
7. The procedures for removal of faults shall be as follows :
 - a. If the fault is of minor nature and has not caused any stoppage of service by the relevant equipment, the second party will rectify the fault within 04 (four) hours from the time of reporting of the fault at Dhaka and 36 hours outside Dhaka.
 - b. If the fault has caused stoppage of service by the relevant equipment, the second party shall change the faulty unit from its reserve stock and take away the faulty unit for subsequent repair. Such replacement will be done within 6 (six) hours from the reporting of the fault for Dhaka and 48 hours for outside Dhaka.
 - c. For any delay beyond the prefixed time line, the first party shall preserve the right to impose financial penalty on the second party. Such penalty shall be as per discretion of the first party.
 - d. If such delays become regular phenomenon, the first party shall have the right to terminate the contract and impose financial penalty on the second party as per discretion of the first party.
 8. The second party shall bear all costs related to such services, including costs for spares & accessories, personnel, transportation, equipment and logistics.
 9. The second party shall provide its personnel with mobile telephone facilities.

Annex-3

Format for Post Guarantee Maintenance Support after Guarantee Period

The format for Post Guarantee Maintenance Support after Guarantee Period shall be exactly same as the format for Maintenance Support during Guarantee Period (Annex-2).

Annex-4

Format for Operation of the network on annual contract basis

The bidder shall quote the price for operating the whole video conferencing network on annual basis. The quotation is mandatory. The price will not be added to the total quoted price for evaluation purpose.

The Contractor shall provide the following service for the operation of the network.

- 1) The service shall cover on-demand operation for all equipment and sites covered by this purchase.
- 2) The services to be provided shall be delivered through deploying following full-time manpower:
 - a) Two Network Engineers to be stationed at Dhaka having sufficient knowledge on the operation of video conferencing network and IP network and two technicians.
 - b) Two full-time personnel to be stationed at each of the Divisional Head Quarters other than Dhaka-one shall be at least Diploma Engineer having operational knowledge of Video conferencing and IP network and one Technician
- 3) The contractor shall bear all costs related to personnel, transportation and logistics for operating the network.

Section-7A

Additional Evaluation Criteria

1. In addition to the terms and conditions of ITT, TDS, GCC and PCC, Tender and Contract Forms, the following terms and conditions shall also be followed in the evaluation of **Section-7**. In case of any contradiction, relevant regulation(s) of PPR-2008 will prevail.
2. During evaluation, TEC shall consider bidders' compliances to various clauses and sub-clauses of Section-7; but shall have the authority to conclude its own decision about such compliances.
3. If the bidder does not give any statement to its compliance to any of the clauses or sub-clauses of Section-7, its' compliance to that clause/ sub-clause (as applicable) shall be treated as "**non compliance**" to that particular clause/ sub-clause.
4. If the bidder puts any condition to his compliance to any of the clauses and/ or sub-clauses of Section-7, its' compliance shall be treated as "**non compliance**" to that particular clause and/ or sub-clause.
5. If the bidder drops any clause or sub-clause in the "**Schedule of Compliance**", its' compliance to that clause/ sub-clause (*as applicable*) shall be treated as "**not complied**" to that particular clause/ sub-clause.
6. TEC shall also consider the contents of various attached documents. If any content of the attached documents contradicts the compliance statement of the bidder to any of the clauses and/ or sub-clauses, it shall be treated as "**non compliance**" to that particular clause and/ or sub-clause. In all of such cases, BTCL's decision shall be final.
7. During evaluation process, if the Bidder proposes to change the equipment model, to supply shortfall quantities, and to supply the proper size/capacity/configuration item without additional cost, to overcome the deviation in the submitted offer that proposal shall not exempt from the penalty points to be earned for the deviations as per relevant clauses.
8. The following deviations will be treated as "**minor deviation**":
 - 8.1 Any deviation which has already been termed as "**minor deviation**".
 - 8.2 The non-compliant of any clause/sub clause having no weight as minor deviation or major deviation or change of substance or critical deviation shall be considered as minor deviation.
 - 8.3 Every item of "minor deviation" shall earn a score of **1(one)** "**penalty point**".
9. The following deviations will be treated as "**major deviation**":
 - 9.1 Any deviation which has already been termed as "**major deviation**".
 - 9.2 Any item of "**major deviation**" shall earn a score of **5(five)** "**penalty points**".
10. The following deviations will be treated as "**Critical Deviation**" :
 - 10.1 Any deviation which has already been termed as "**critical deviation**".
 - 10.2 If the bidder puts any condition(s) in the price offer.
 - 10.3 Any item of "**Critical Deviation**" shall earn a score of **25 (twenty five)** "**penalty points**".

-
11. If the bidder refuses to provide answers to any requested clarification(s), it will be treated as **“change of substance”** of the bid.
 12. A bid containing any item of **“change of substance”** shall be treated as **“substantially non responsive”**.
 13. The penalty points earned will be added to get total penalty points. If the total penalty points is more than 75 (Seventy Five), the whole bid shall be treated as **“Substantially Non-Responsive”** and if the total penalty points is less than or equal to 75 (Seventy Five), it will be treated as **“Responsive”**.
 14. BTCL’s decision to treat any bid as **“Substantially Non-Responsive”** shall be final.

Section 8 : Drawings

Diagrams of the proposed video conference system are given in the subsequent 8 (eight) pages.

Central Node Connectivity Diagram

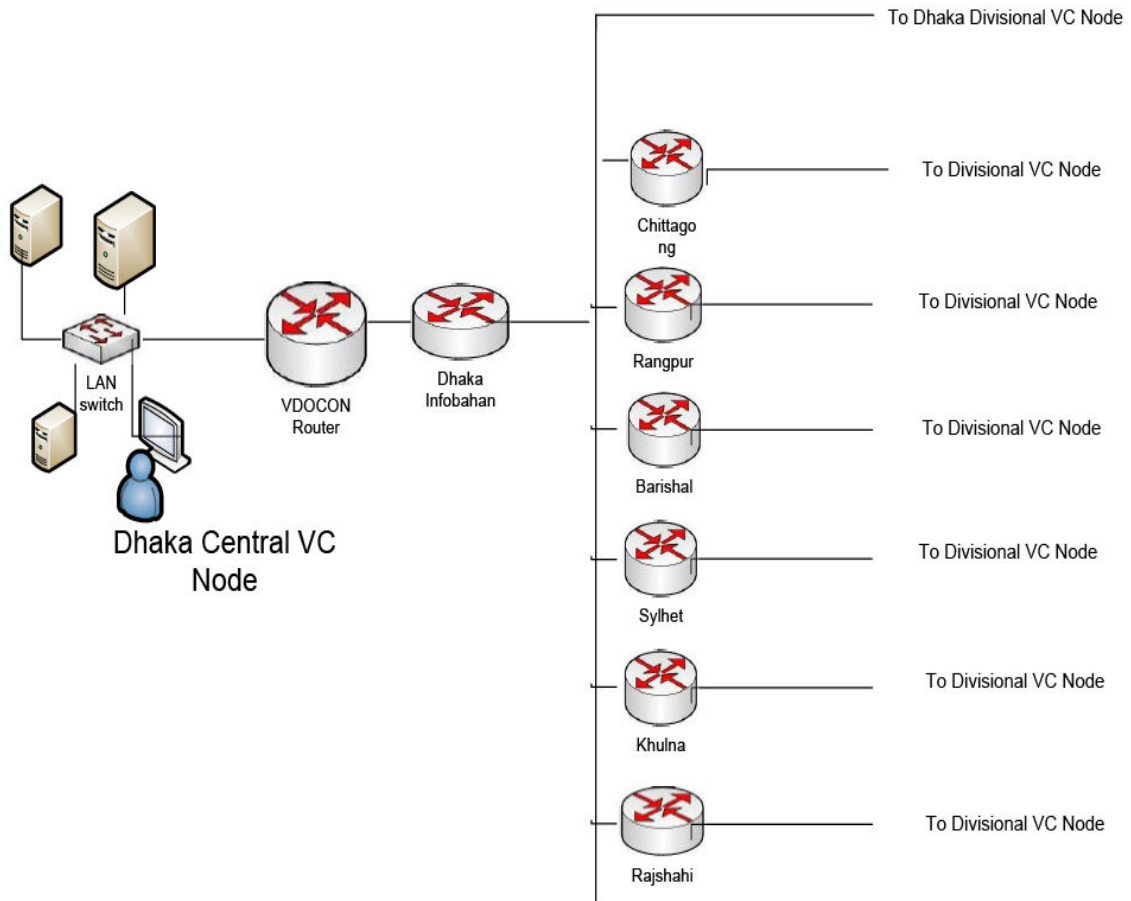

Network Diagram of Dhaka Division

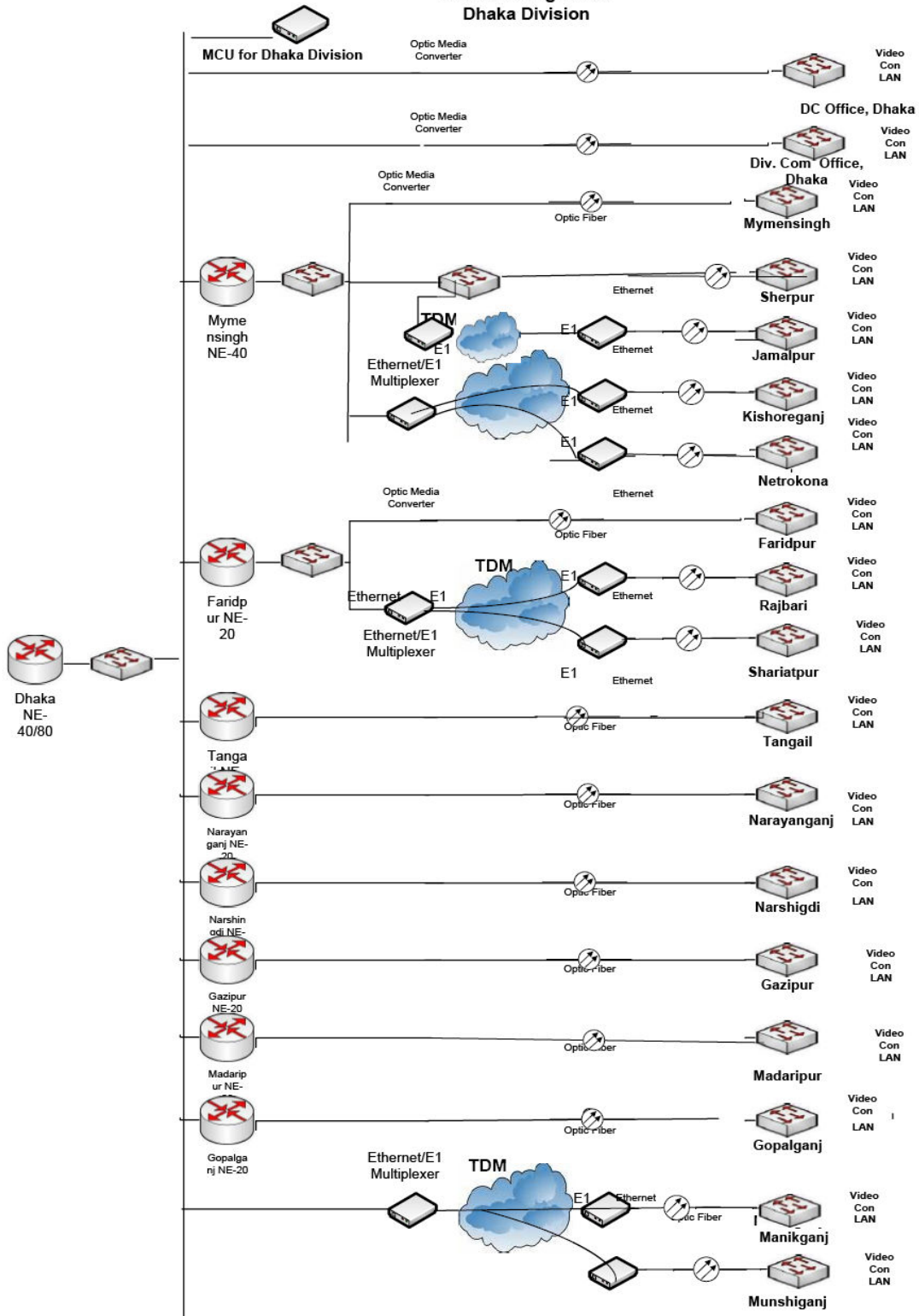

Network Diagram of Ctg Division

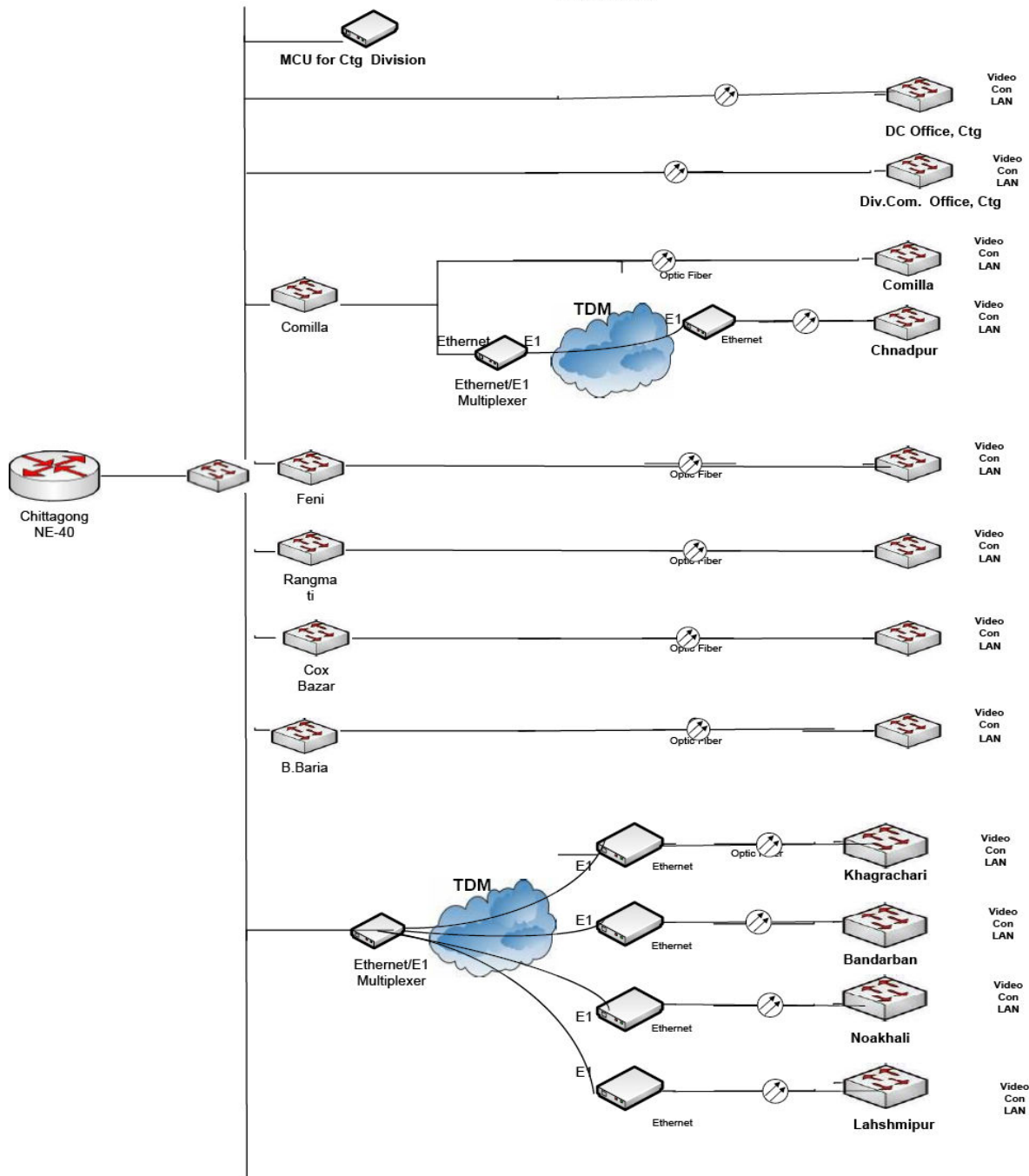

Network Diagram of Khulna Division

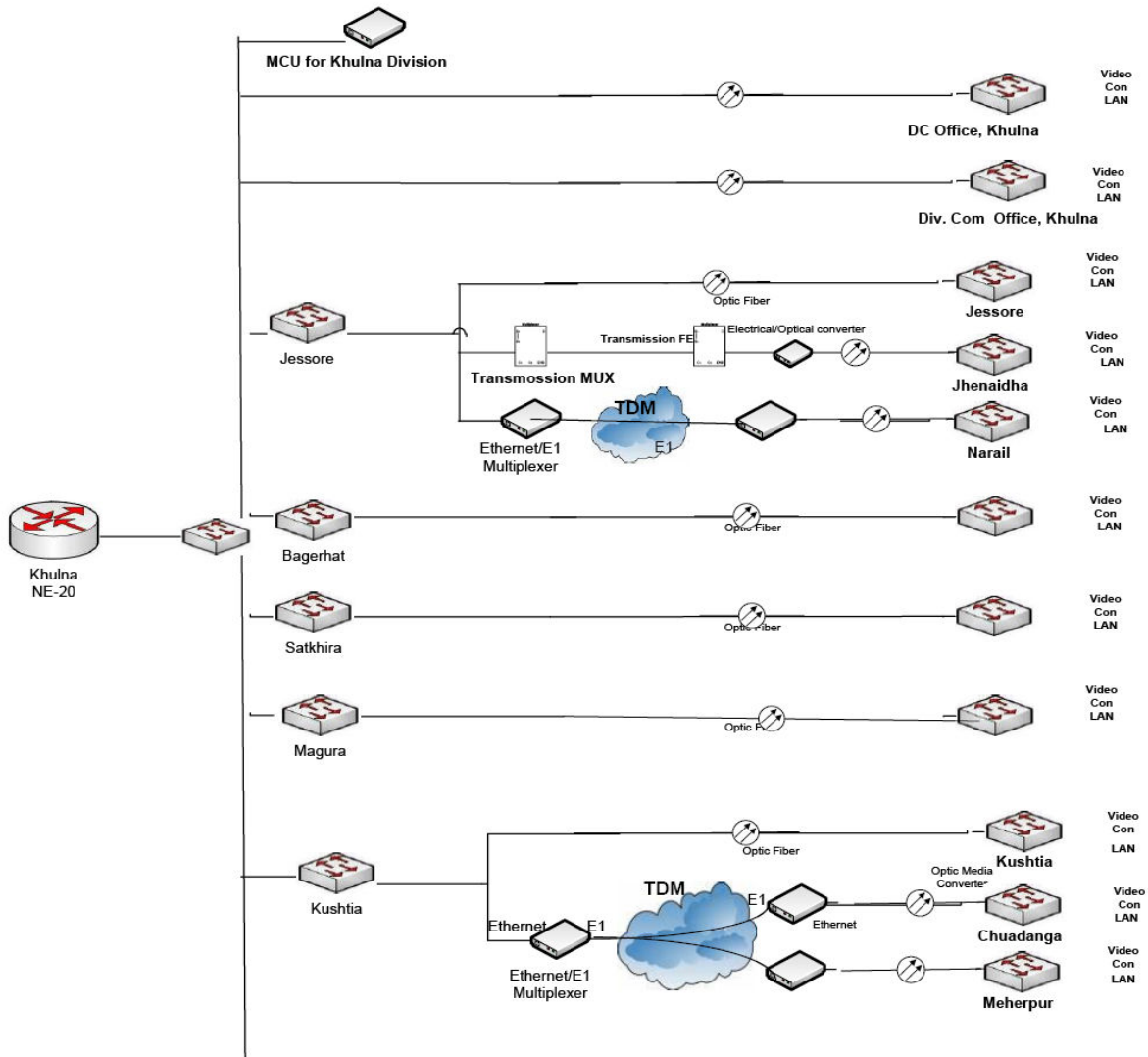

Network Diagram of Rajshahi Division

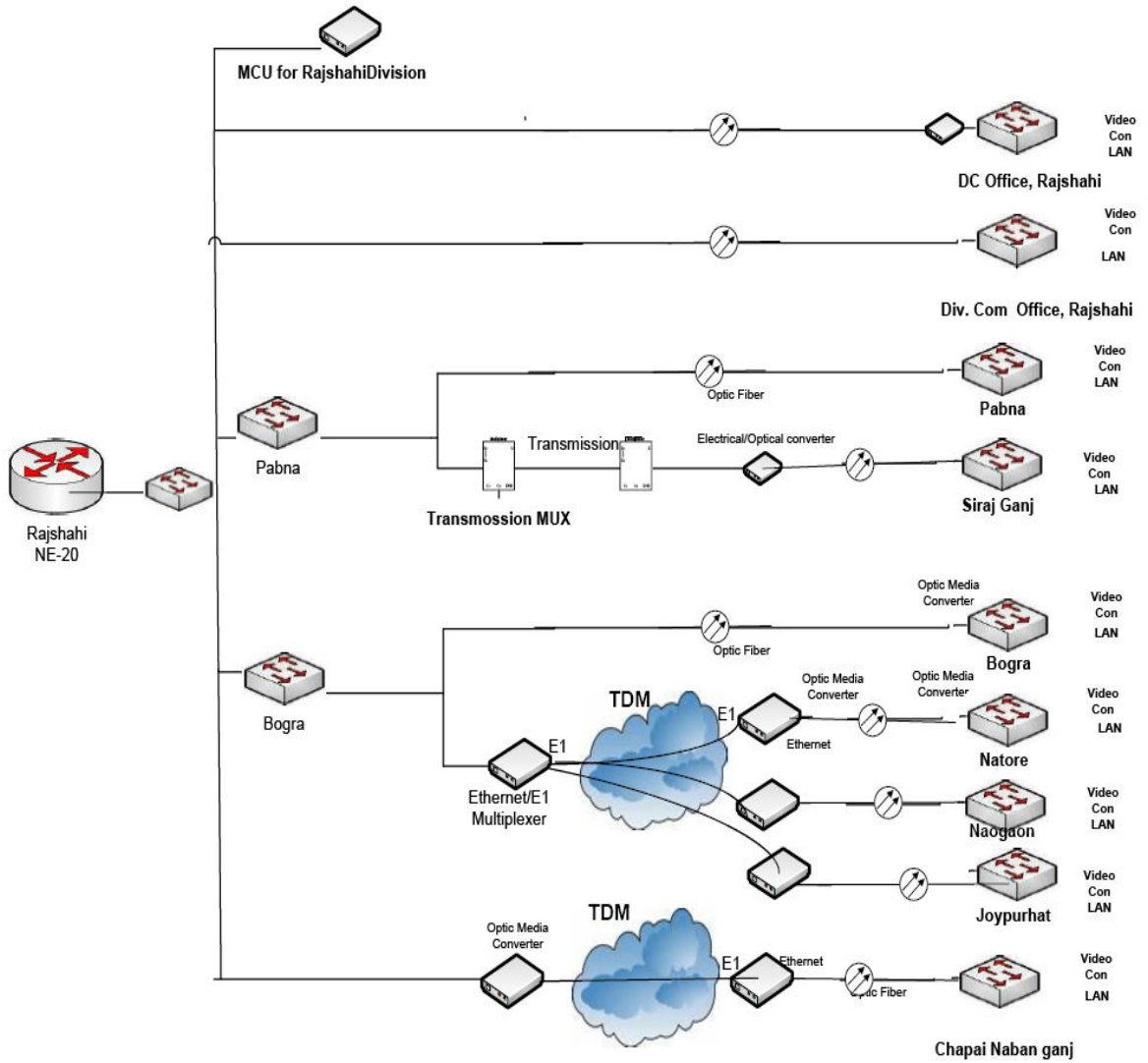

Network Diagram of Rangpur Division

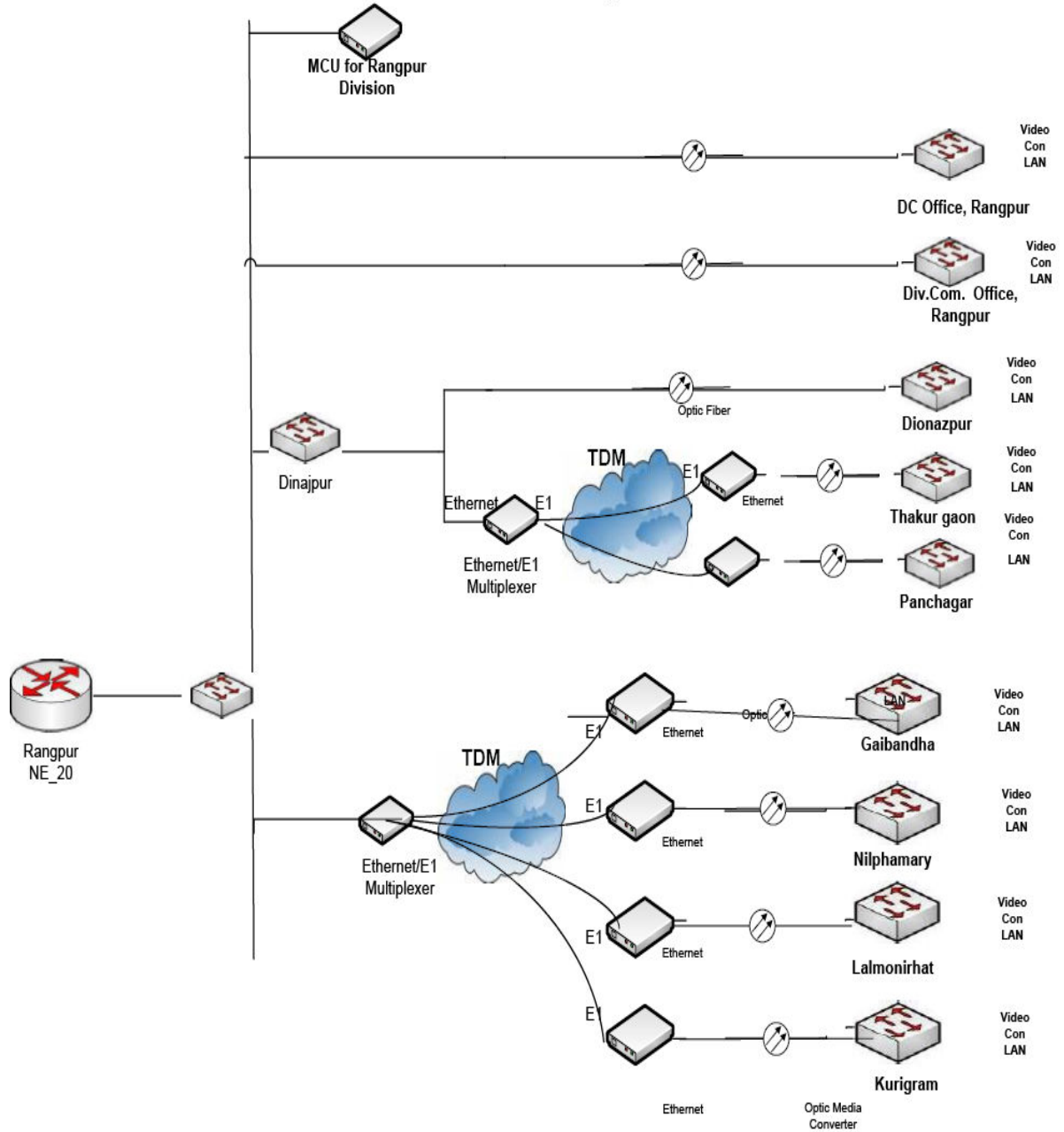

Network Diagram of Barishal Division

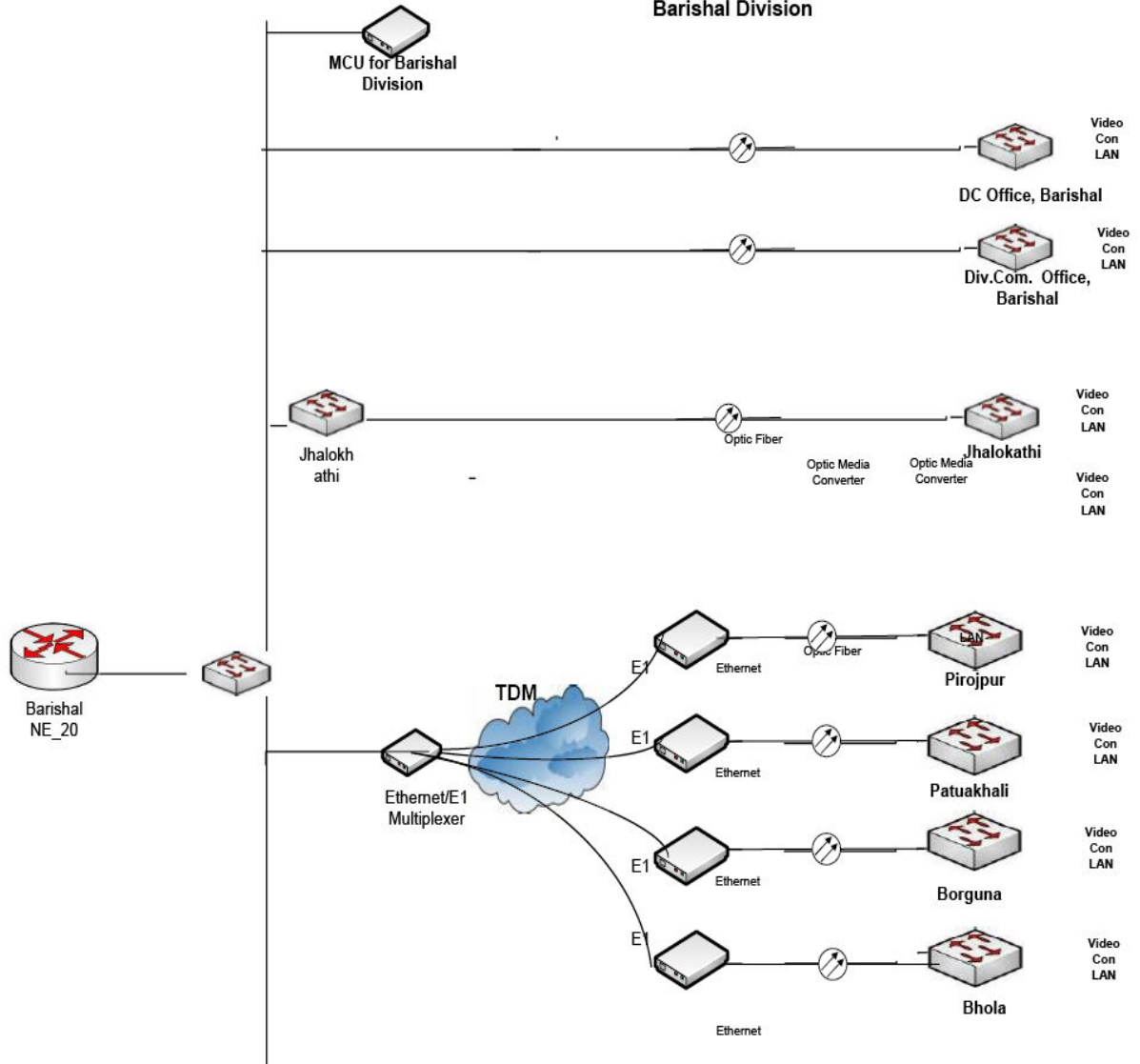

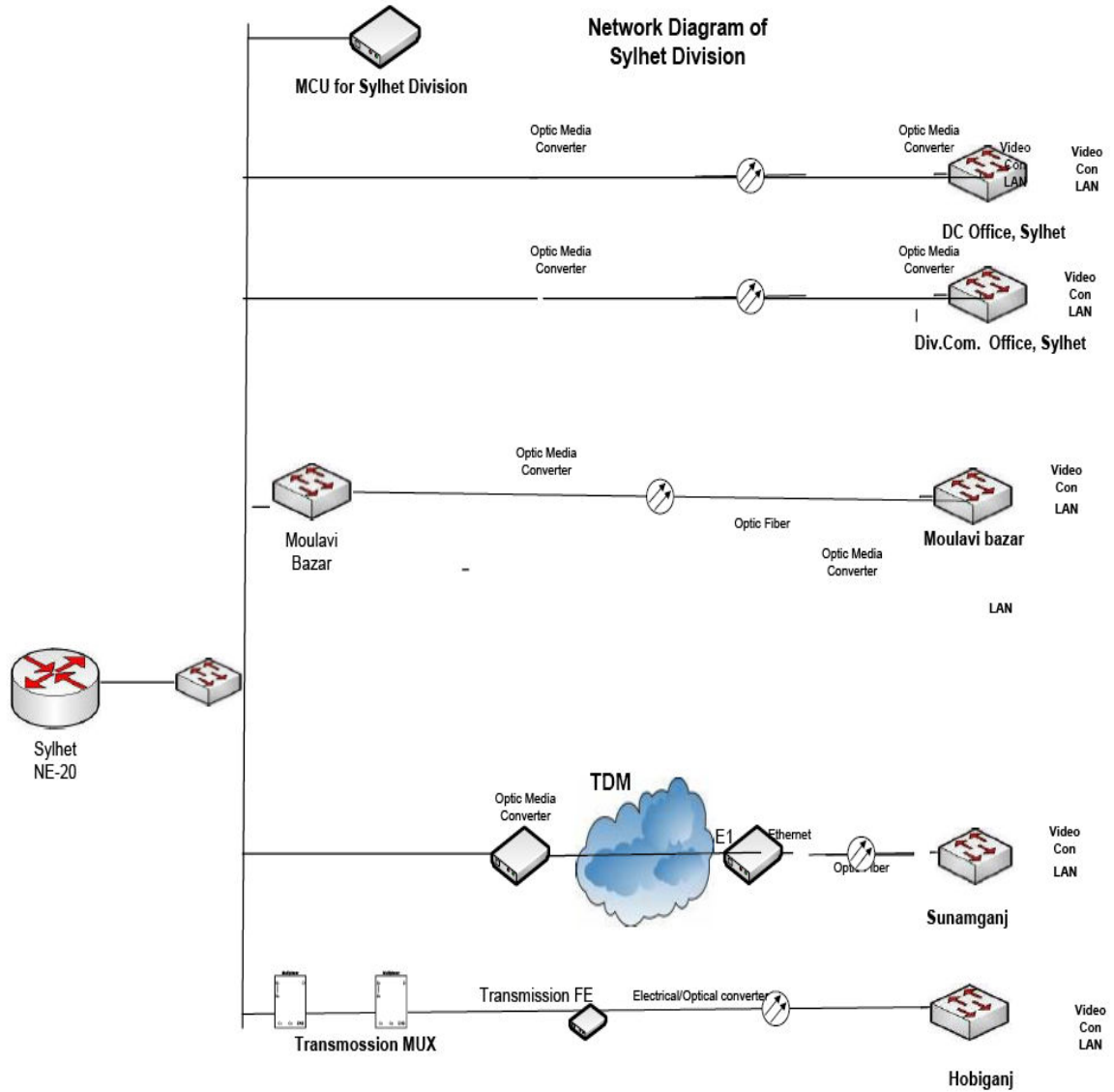

:: END OF DOCUMENT::